



**2009-14, Dodge, 12”  
Mud Flap Set, 5/8” Offset, Front  
Mounting Diagram & Instructions  
Part #756860 (Powder Coated)**

**IMPORTANT:**

**Manufacturer is not responsible for negligent use of vehicle with mud flaps installed, including over-tightening of screws and bolts causing damage to vehicle or mud flaps.**

**NO-DRILL SYSTEM**

**TOOLS REQUIRED-**

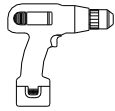

*Electric or Chargeable  
1/2” or 3/8” Drill*



*3/8” Socket Driver*



*1/4 ” Drill Bit*

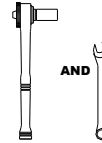

*5/16 & 3/8” Open End  
Wrench & Socket Wrench*

**SCREWS / FASTENERS / WASHERS / FLAPS - PARTS BAG # 755864**

*a) (1) Flap Assembly,  
Front, DS  
Part #756861*

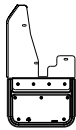

*b) (1) Flap Assembly  
Front, PS  
Part #756862*

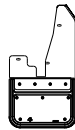

*c) (2) Screw, Machine  
#10 x 1”, SS  
Part #012022*



*d) (4) Washer, Flat  
0.203” x 1”, SS  
Part #018031*



*e) (2) Washer, Lock  
#10, Helicoil, SS  
Part #024001*



*f) (2) Hex Nut  
#10, SS  
Part #025003*



**INSTALLATION** *(For ease of installation it is suggested that the wheel be removed)*

1. Before you install your Precision Mud Flap, see the diagram and parts list for all necessary parts. Cut the protective plastic and peel away from the stainless steel. Start on the driver’s side.
2. Remove two (2) factory screws #4 & #5, on the wheel flare as shown in the diagram and reinstall the two (2) factory screws on holes #1 & #2, through the factory holes #4 & #5. Loosely secure at this point.
3. Square the flap with the tire, while putting pressure against the wheel flare, then tighten the two (2) factory screws on holes #1 & #2.

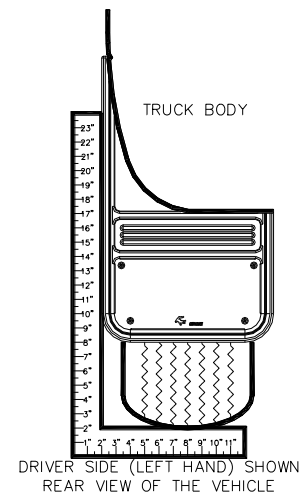

4. Drill  $\frac{1}{4}$ " hole (1), from hole #3 through the factory plastic liner and secure that hole with one (1) machine screw #012022, two (2) flat washers #018031, one (1) lock washer #024001 and one (1) hex nut #025003.

**Caution:** Insure that you have access from behind the factory plastic liner to install and tighten the washers and nuts before drilling.

5. Repeat procedure for the passenger side.

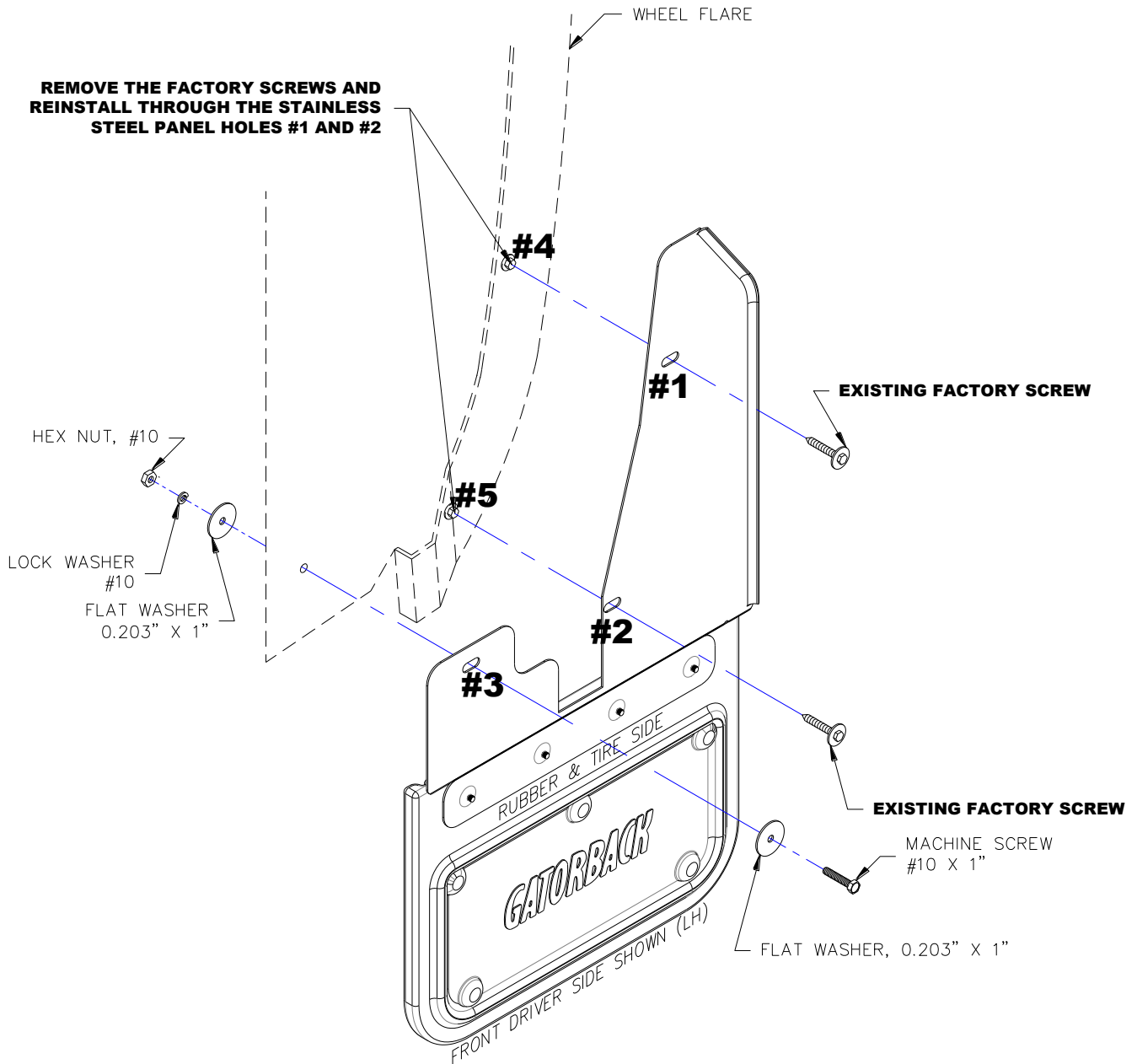

**IMPORTANT:**

Manufacturer is not responsible for negligent use of vehicle with Mud Flaps installed, or over tightening of screws and bolts causing damage to vehicle or mud flaps.