



2004-14, Ford F-150 Front Upper Mount Kit 5/8" Offset Mounting Instructions GB756683

IMPORTANT:

Manufacturer is not responsible for negligent use of vehicle with mud flaps installed, or over-tightening of screws and bolts causing damage to vehicle or mud flaps.

TOOLS REQUIRED

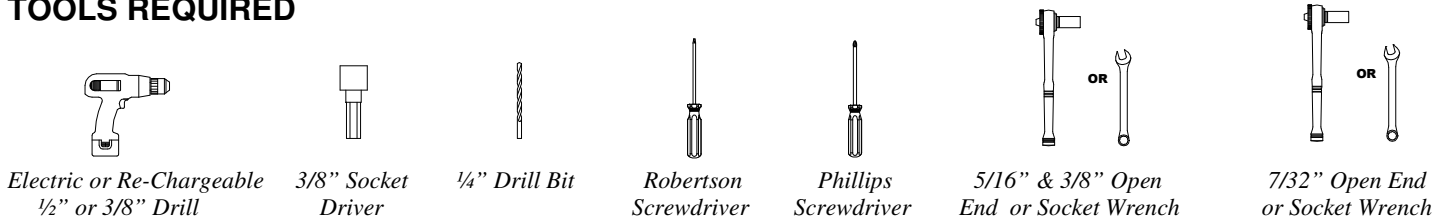

KIT CONTENTS:

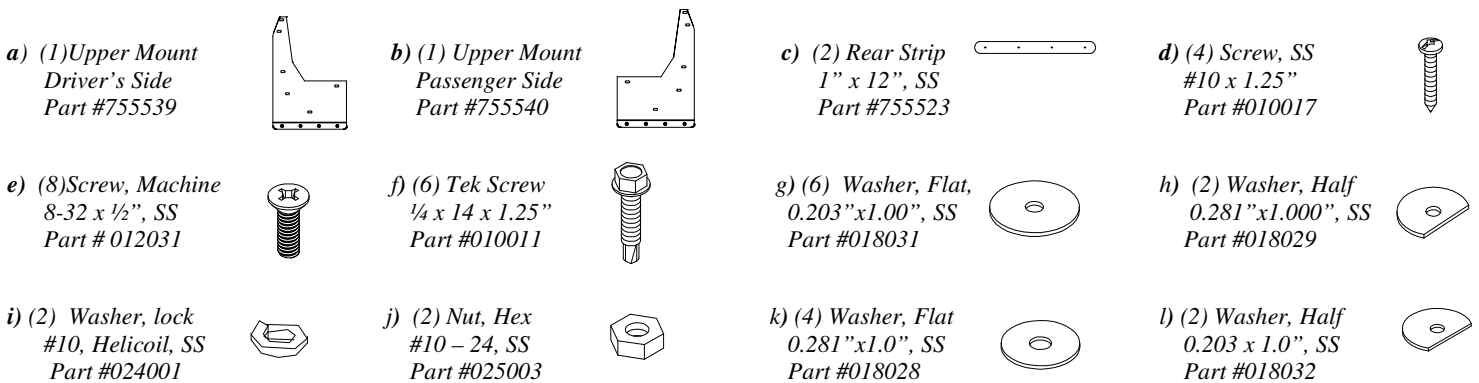

**Before you install your Mud Flap, see the above diagrams and parts list for all necessary parts.
Start on the driver's side.**

INSTALLATION

For ease of installation, it is suggested that the wheel be removed.

1. Before you install your Mud Flaps, see the diagram and parts list for all necessary parts. Cut protective plastic and peel away from the stainless steel. Start on the Driver's side.
2. Remove the factory screws #7 & #8 on the wheel flare, as shown on the diagram and discard. Install one (1) sheet metal screw #010017 and one (1) washer #018031 on hole #4 through previously, screw removed, hole #7. Loosely secure at this point.
3. Install one (1) sheet metal screw #010017 and one (1) washer #018032 on hole #5 through previously, screw removed, hole #8. Loosely secure at this point.



4. Square the flap with the tire and push the flap up against the wheel well.

Be sure the flap is straight!

5. Fasten the flap with the two (2) Tek Screws #010011 and two (2) Washers #018031 on holes #2 & #3. Use one (1) Tek Screw #010011 and one (1) Washer #018031 on hole #1.
6. Drill a 1/4" hole from hole #6 through the factory plastic guard and fasten hole #6 with one (1) Machine Screw #012022, two (2) Washer #018031, one (1) Lock Washer #024001 and one (1) Hex Nut #02500 and tighten. Tighten the remaining factory screws on holes #5 & #6.

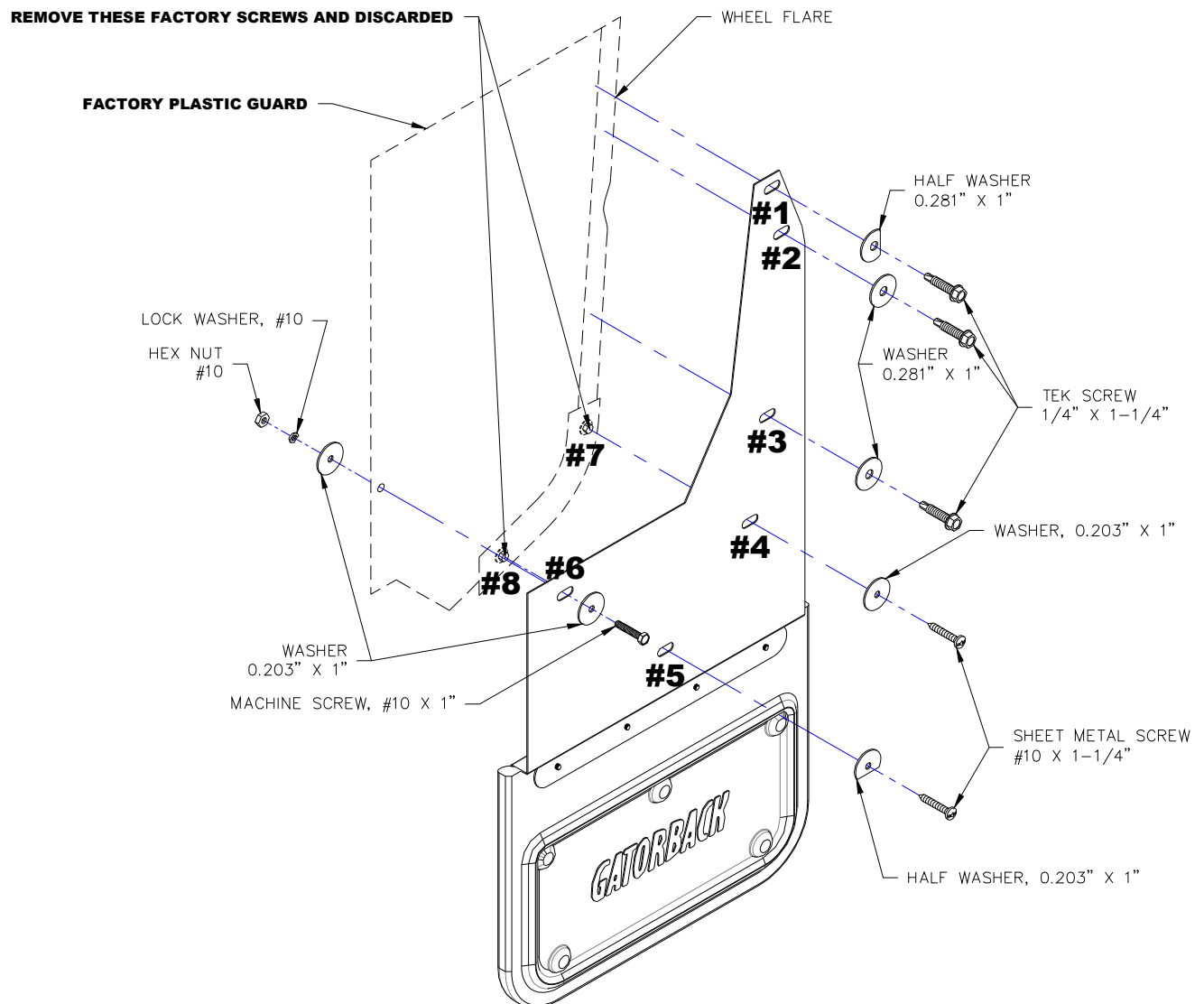

- ✓ Check all fasteners for tightness. Repeat procedure on the passenger side
-