



21-C Ford Bronco

Mud Flap Set, Front

Mounting Diagram & Instructions

For use with vehicles without running boards

Not recommended for base models with 30" tires

IMPORTANT:

Manufacturer is not responsible for negligent use of vehicle with mud flaps installed, including over-tightening of screws and bolts causing damage to vehicle or mud flaps.

TOOLS REQUIRED-



#2 Phillips Bit
Or Screwdriver

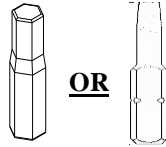

T25 Torque Socket
or 5/32" Allen Socket

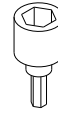

18mm Socket

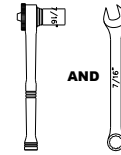

7/16" Open Wrench
and Socket Wrench



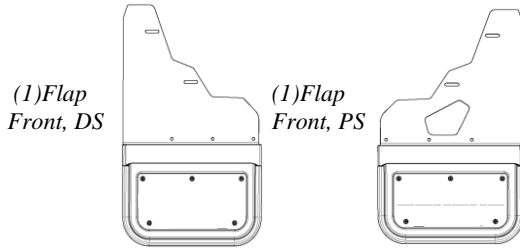



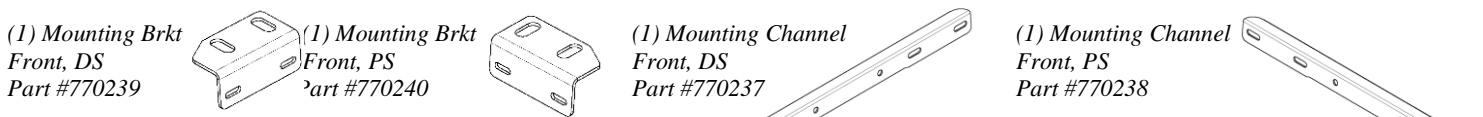
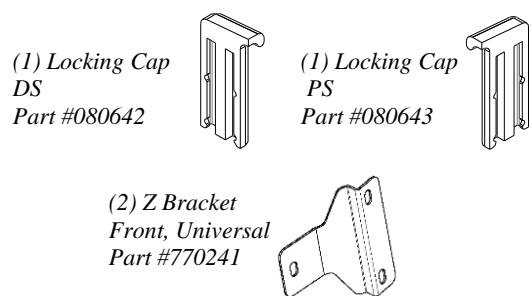

FLAPS/BRACKETS/LOCKING CAPS

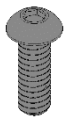

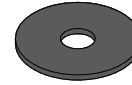
Note: For vehicles with factory rock rails, hole will be cut in the mud flap as shown in passenger side drawing.

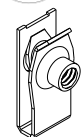
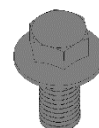
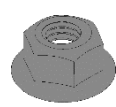

PARTS BAG # 770278

- a) (12) Button Hd. Screw 1/4"-20 x 3/4", SS, Blk Ox. Part #014081 
- b) (2) Button Hd. Screw 1/4"-20 x 2", SS, Blk Ox. Part #014083 
- c) (4) Capscrew, SS Blk Ox. 1/4"-20UNC x 3/4" Part #014070 
- d) (4) Washer, Flat, 1/4" x 1"OD, SS, Blk Ox. Part #018069 
- e) (20) Washer, Nylon 1/4" x 5/8" Blk Part #054071 
- f) (2) Washer, Offset 0.281" x 1.5" SS, Blk Ox. Part #018087 
- g) (2) Spacer, Nylon, Blk 1/4" x 1/2" x 7/8" Part #054082 
- h) (12) Hex Nut 1/4"-20, SS, Blk Ox. Part #025038 
- i) (12) Washer, lock 1/4" Helicoil, SS, Blk Ox. Part #024012 
- j) (6) Spring Nut 1/4"-20UNC, 0.84" Reach Part #028011 
- k) (4) Hex Bolt M 12 x 25mm, SS Part #014079
Only used on vehicles without crash bar extension. 
- l) (4) Flange Nut SS, M 12, Serrated Part #025039
Only used on vehicles with crash bar extension. 



INSTALLATION *(For ease of installation it is suggested that the wheel be removed)*

1. Before you install your mud flap and bracket set, see the diagrams and parts list for all necessary parts. Start on the driver's side.
2. Secure the mounting channel assembly through holes #4 to #6 to the mud flap through holes #1 to #3 using a screw (a) and secure with a nylon washer (e), lock washer (i) and hex nut (h). (See Diagram #1)

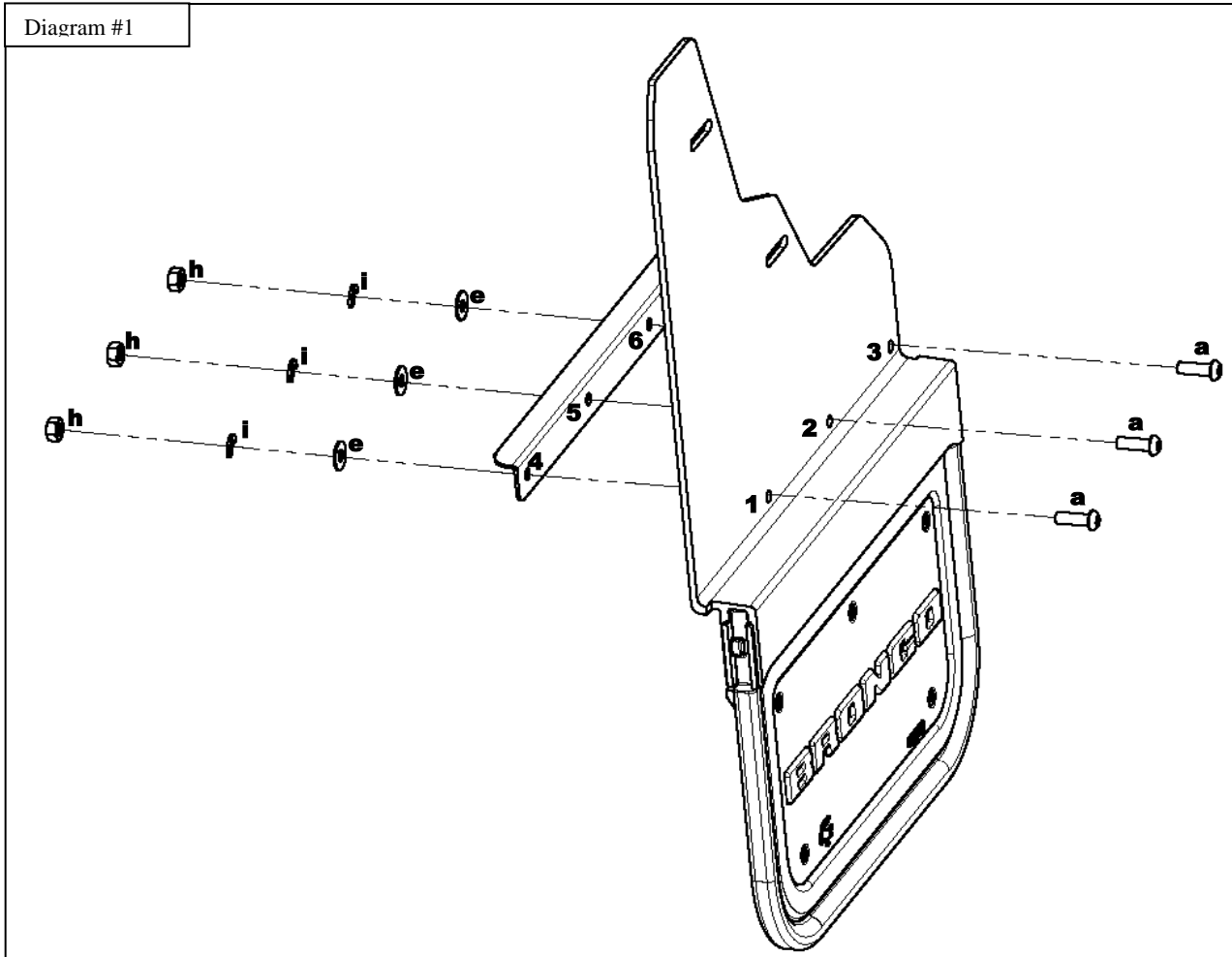

3. Secure the mounting bracket through holes #7 & #8 to the mounting channel through holes #9 & #10 using capscrew (c), and nylon washer (e), and secure with a nylon washer (e), lock washer (i), and hex nut (h). (See Diagram #2)

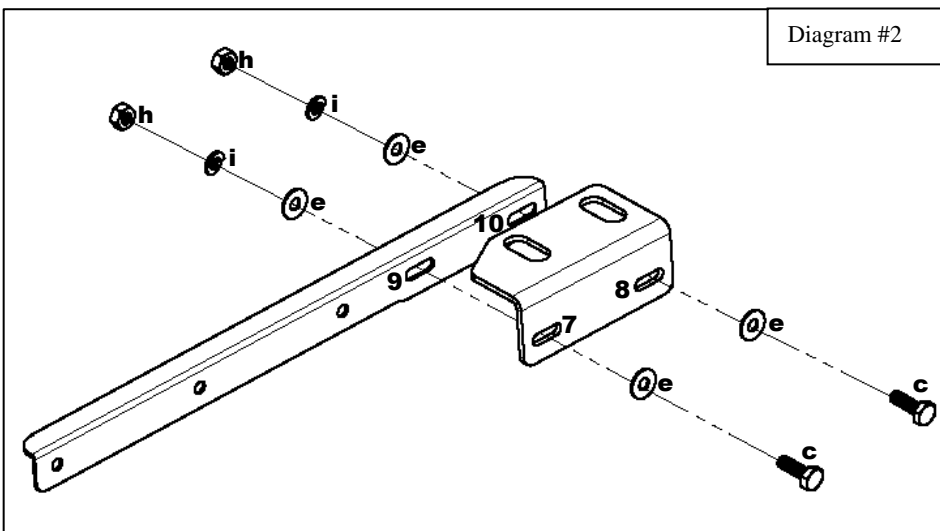

4. Loosely install mud flap hole #11 to Z-bracket hole #12 using a button head screw (a) and offset washer (d) and secure using a nylon washer (e), lock washer (i) and hex nut (h). (See Diagram #3)

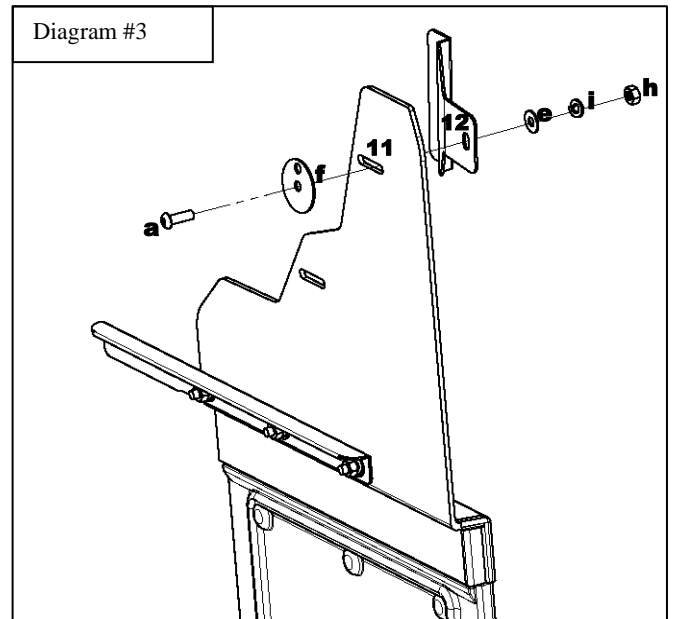

5. Remove the three lower factory push pins from holes #13 to #15 by unscrewing the center and then pulling the push pin out.
6. Lift the factory liner and install three spring nuts (j) over factory holes #13 to #15 (See Diagram #4)

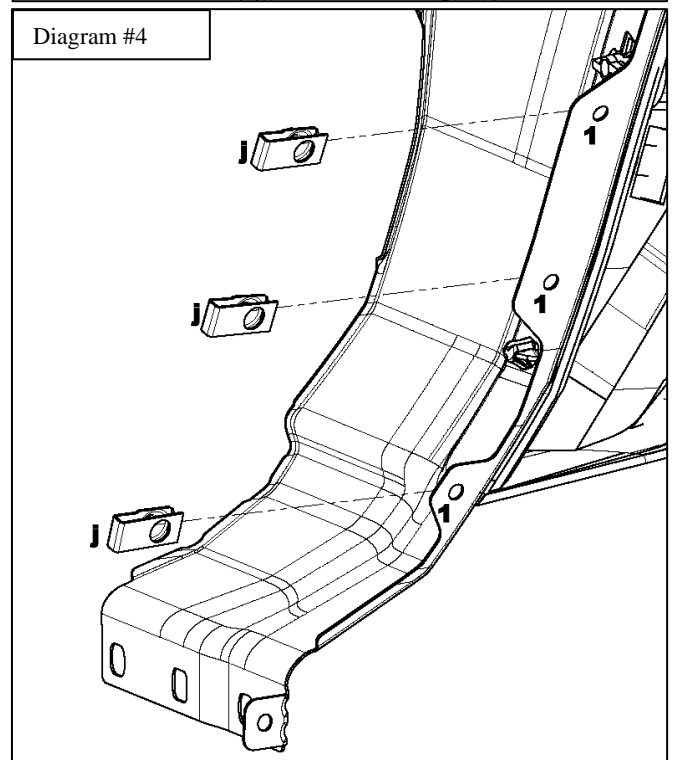

- 7a. For vehicles **with crash bar**, loosely install the mounting bracket through holes #16 & #17 to the factory crash bar mount bolts using an M12 serrated flange nut (l). (See Diagram #5a)

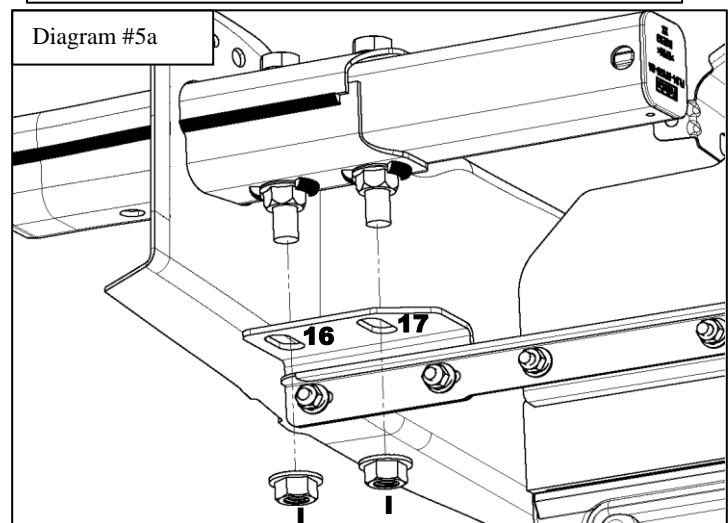

- 7b. For vehicles **without crash bar**, loosely install the mounting bracket through holes #16 & #17 to the factory crash bar mount holes #18 & #19 using an M12 bolt (k). (See Diagram #5b)

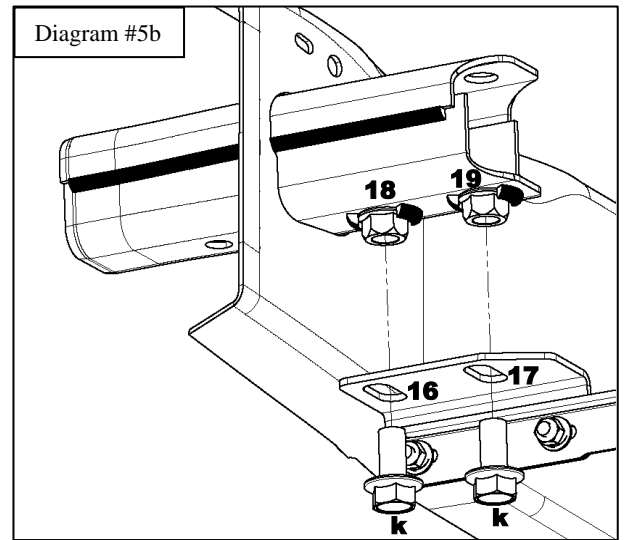

8. Loosely install mud flap through hole #20, flat washer (d), and spacer (g) into previously installed spring nut (j) on factory hole #15 using a button head screw (b) and flat washer (d). (See Diagram #6)

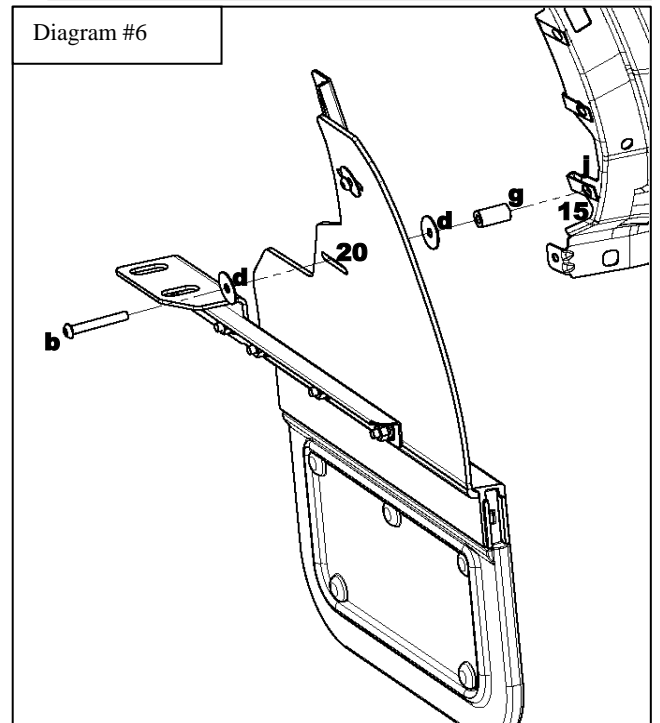

9. Install Z-bracket holes #21 & 22 to spring nuts (j) on holes #13 & #14 using button head screw (a) and nylon washer (e). (See Diagram #7)
10. With a square or other levelling tool, ensure that the flap is level.
11. Carefully tighten all fasteners, ensuring that the flap remains level.
12. Repeat procedure on the passenger side.

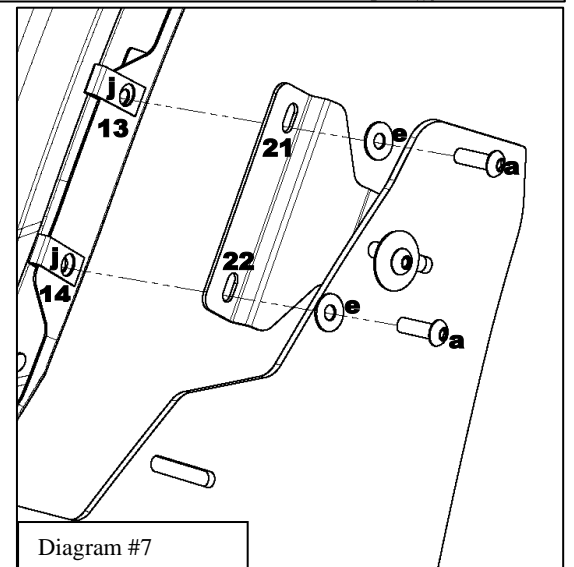

Please check out our YouTube channel to see an install video for this application.





Gatorback Mud Flaps by Truck Hardware Ltd.

LIMITED WARRANTY

All Ford part numbers provided by Truck Hardware Ltd. are warranted to be free from defects in materials or workmanship on products properly installed per the installation instructions provided with the product. This warranty covers repair or replacement of any defective product at no charge during the applicable warranty period listed below. Labor for replacement or service of defective product is not paid or reimbursed by Truck Hardware Ltd.

WARRANTY PERIOD		
	USA	Outside USA
Product which appears on New Vehicle Monroney Label (window sticker)	Coverage which matches new vehicle warranty---Ford - 3 years or 36,000 miles whichever comes first; Lincoln 4 years or 50,000 miles whichever comes first	Coverage which matches new vehicle warranty ---Ford - 3 years or 60,000 kilometers whichever comes first; Lincoln 4 years or 80,000 km whichever comes first
Part purchased and installed during or after the original vehicle warranty	Whichever of the following options provides the greater benefit to the customer: 1) 2 years / unlimited miles or 2) The remainder of the new vehicle warranty	Whichever of the following options provides the greater benefit to the customer: 1) 2 years / unlimited kilometers or 2) The remainder of the new vehicle warranty

This limited warranty does not cover any damage, defect or malfunction caused by misuse, abuse, accident, improper installation, modification or improper or lack of maintenance. Incidental and consequential damages are not recoverable under this warranty. This warranty offers you specific legal rights. You may have additional or other rights as which vary from state to state or province to province.

If you experience a warranty issue with this product please visit your Ford dealer. If the repair is covered by the warranty above and completed by the dealership, labor is also covered by Ford -- Ford Warranty and Policy – Section 3.

Please note that Truck Hardware Ltd. has replacement component parts available to assist consumers and dealers to resolve warranty and non-warranty issues as quickly as possible.

Note to dealer:

Ford dealers should contact Truck Hardware Ltd. by phone at 1-800-661-8208 and ask to speak to the warranty administrator or by email to: info@truckhardware.ca.