

**IMPORTANT:**

**Manufacturer is not responsible for negligent use of vehicle with mud flaps installed, including over-tightening of screws and bolts causing damage to vehicle or mud flaps.**

**TOOLS REQUIRED-**

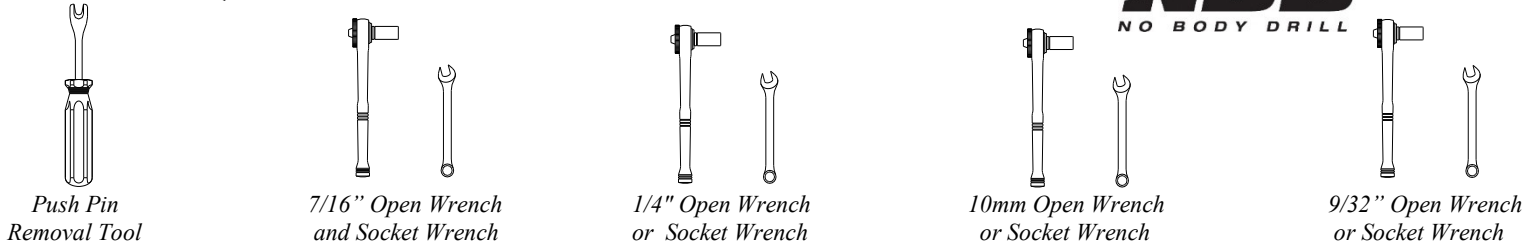

**FLAPS AND BRACKETS**

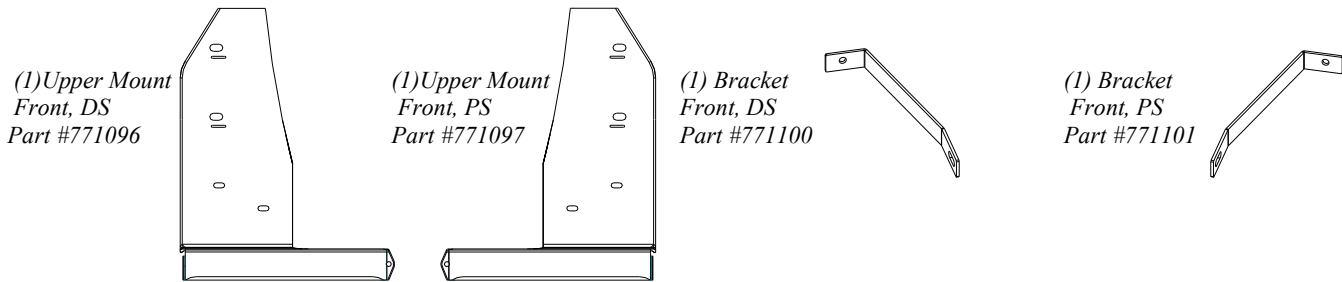

Please note: There will be a plastic piece in the upper mount channel. Please remove and discard.

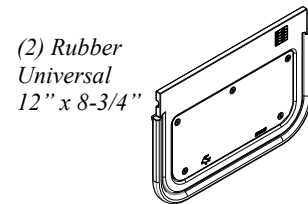
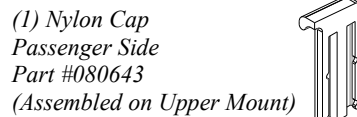
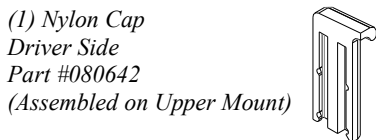

**PARTS BAG #771083**

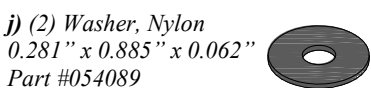
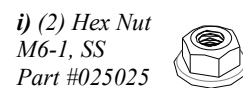
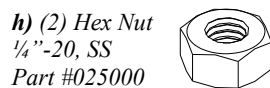
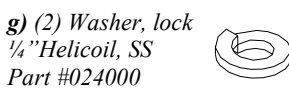
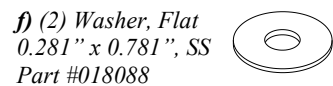
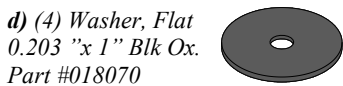
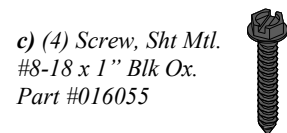
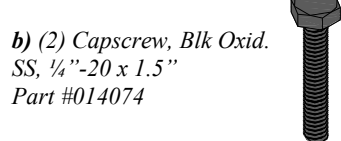
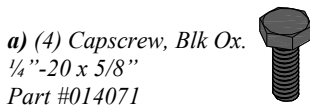

## Installation

Before you install your Mud Flap Set, see the diagrams and parts list for all necessary parts.

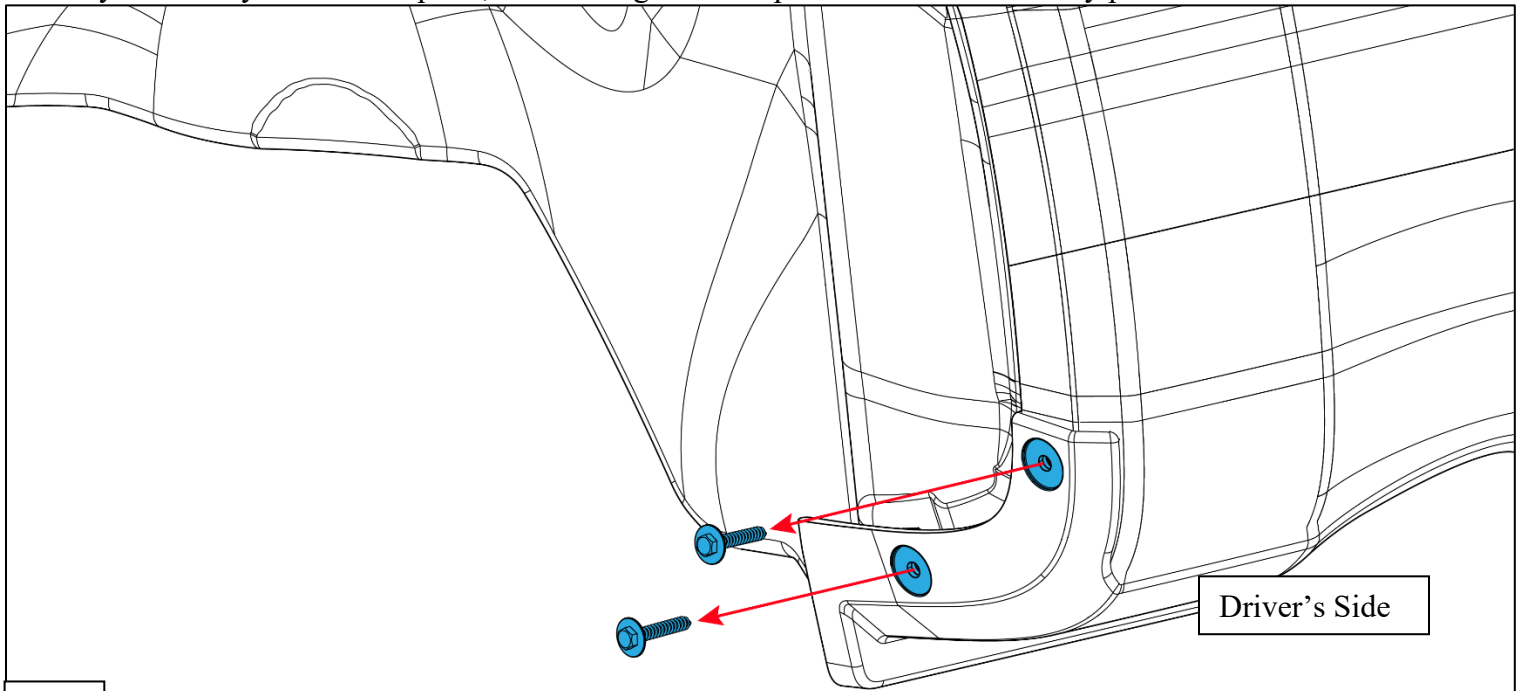

1-1 Remove factory screws.

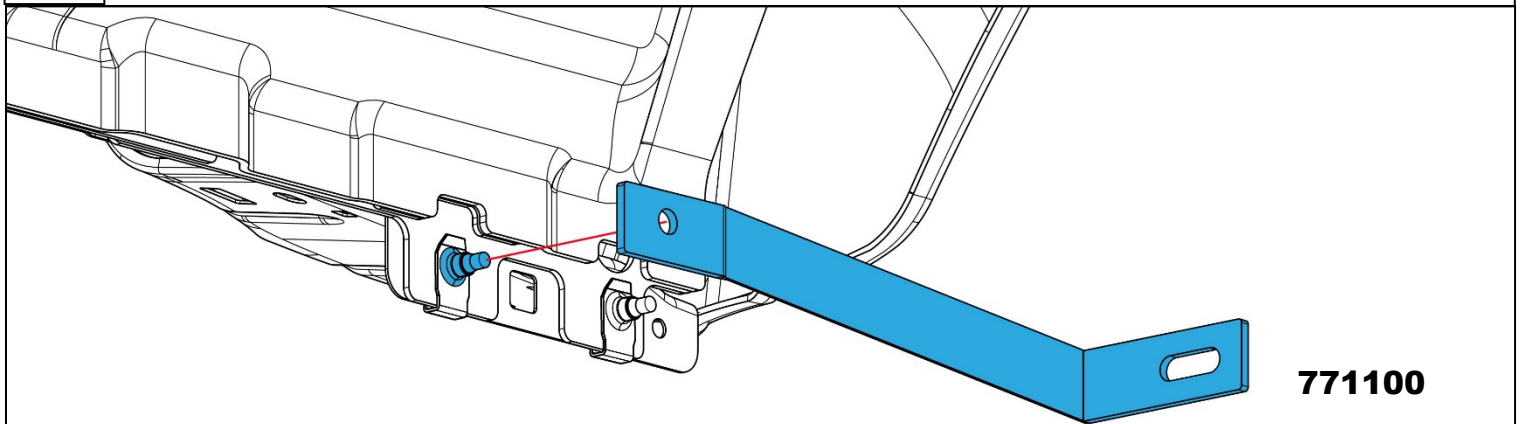

2-1 Attach bracket as shown to the pinch weld on the inner part of the fender.

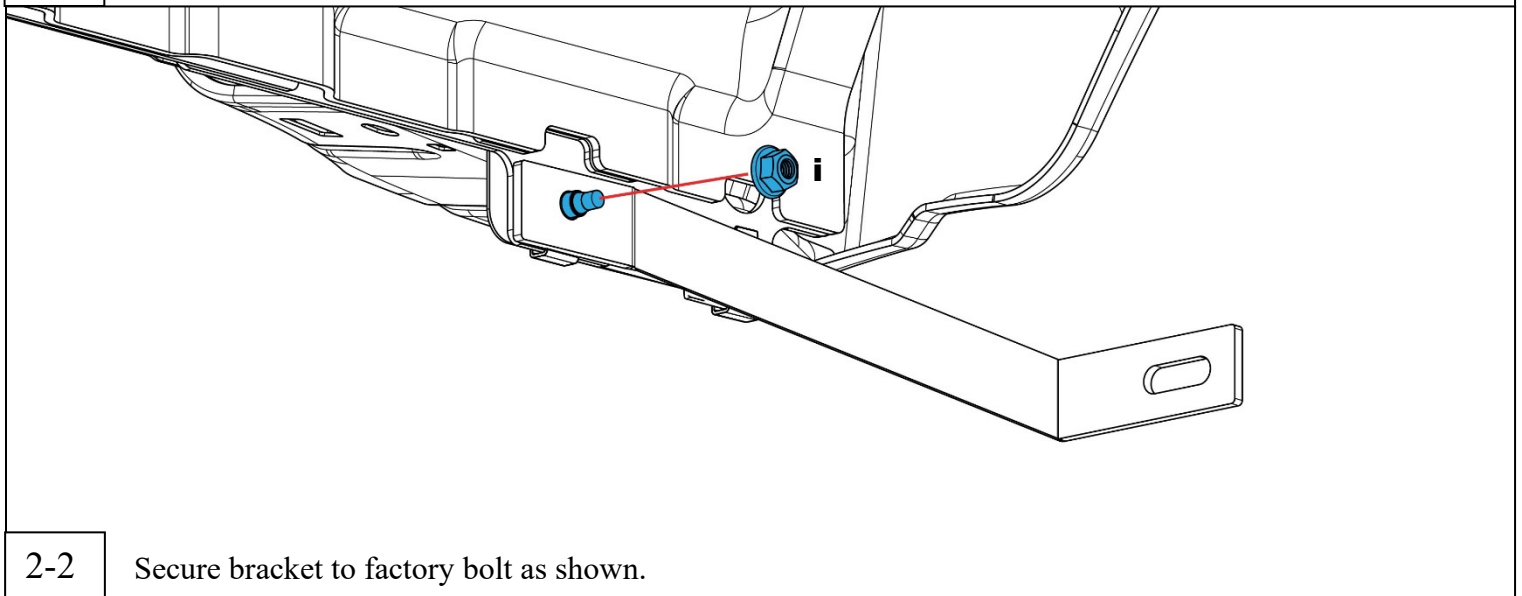

2-2 Secure bracket to factory bolt as shown.

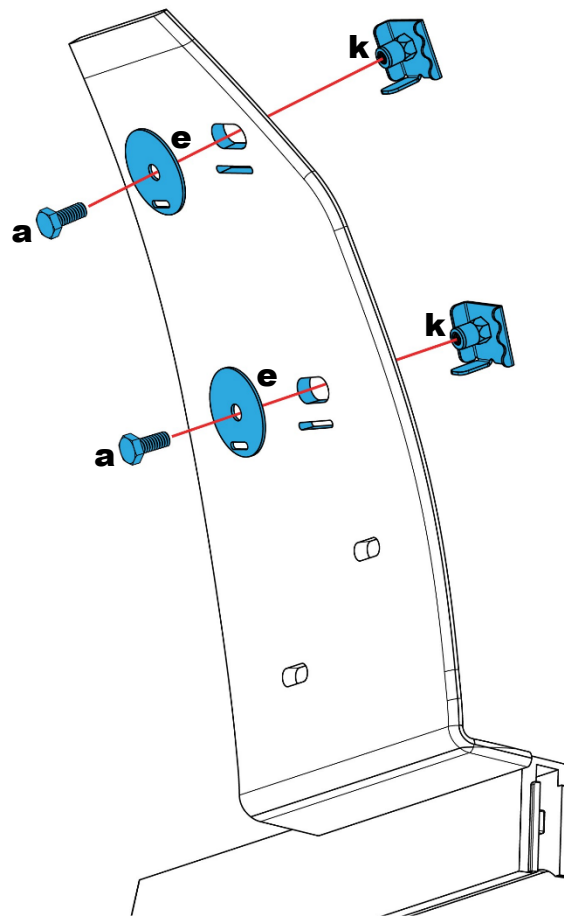

3-1 Loosely install mount clips to top 2 mud flap holes. Do not install on the fender lip at this time.

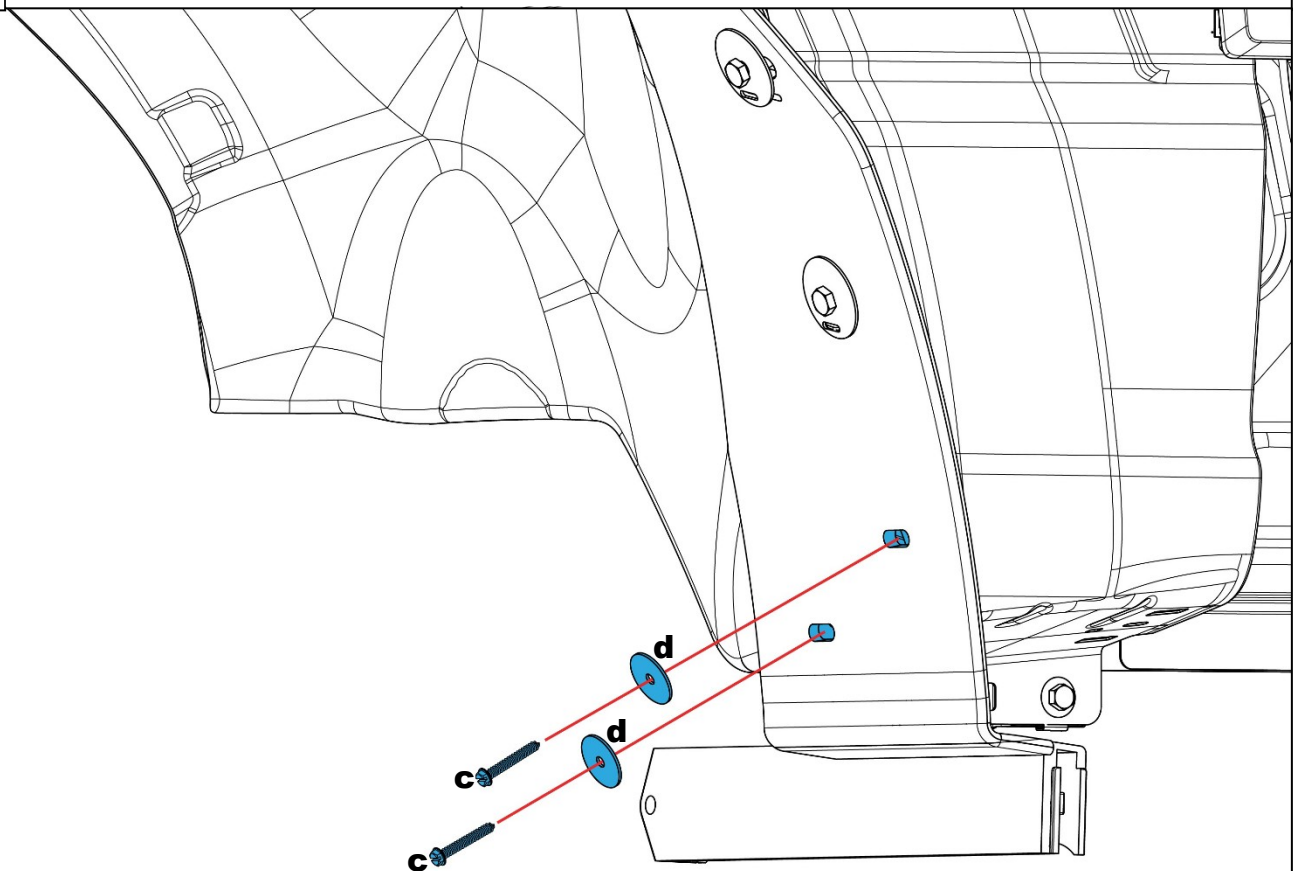

4-1 Install these two mud flap holes to the factory holes as shown.

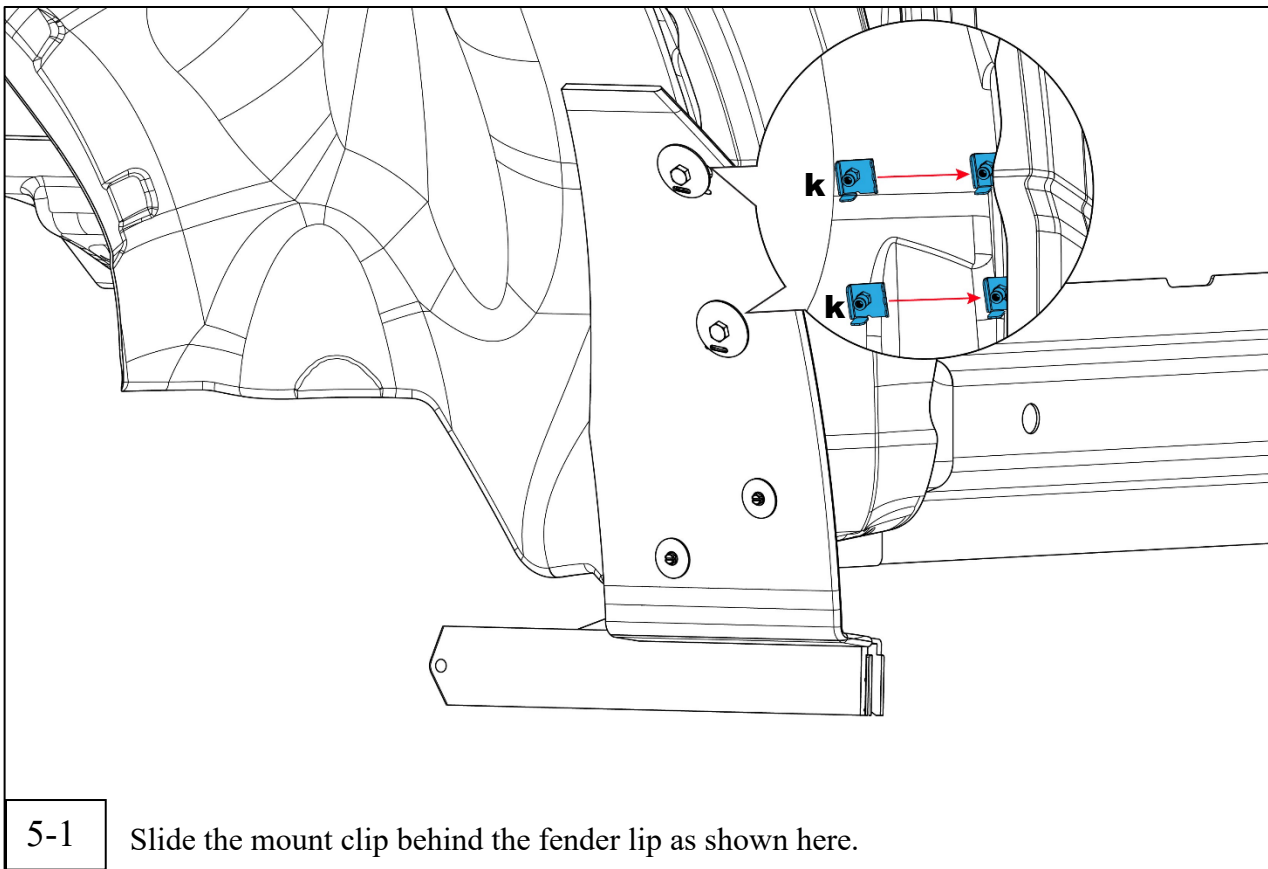

**5-1** Slide the mount clip behind the fender lip as shown here.

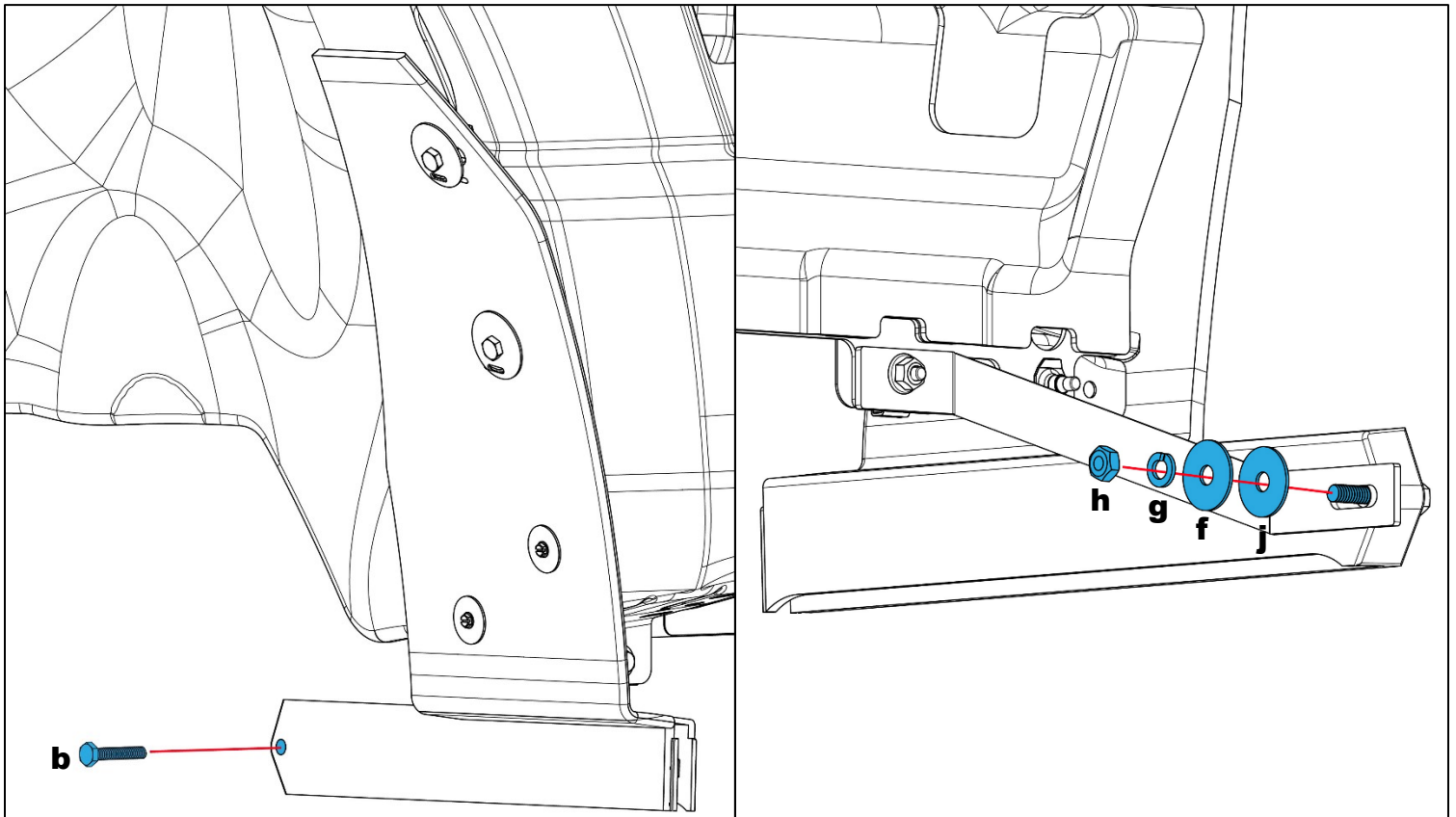

**6-1** Install hardware as shown.

**6-2** Secure hardware installed in step 6-1 to the bracket as shown.

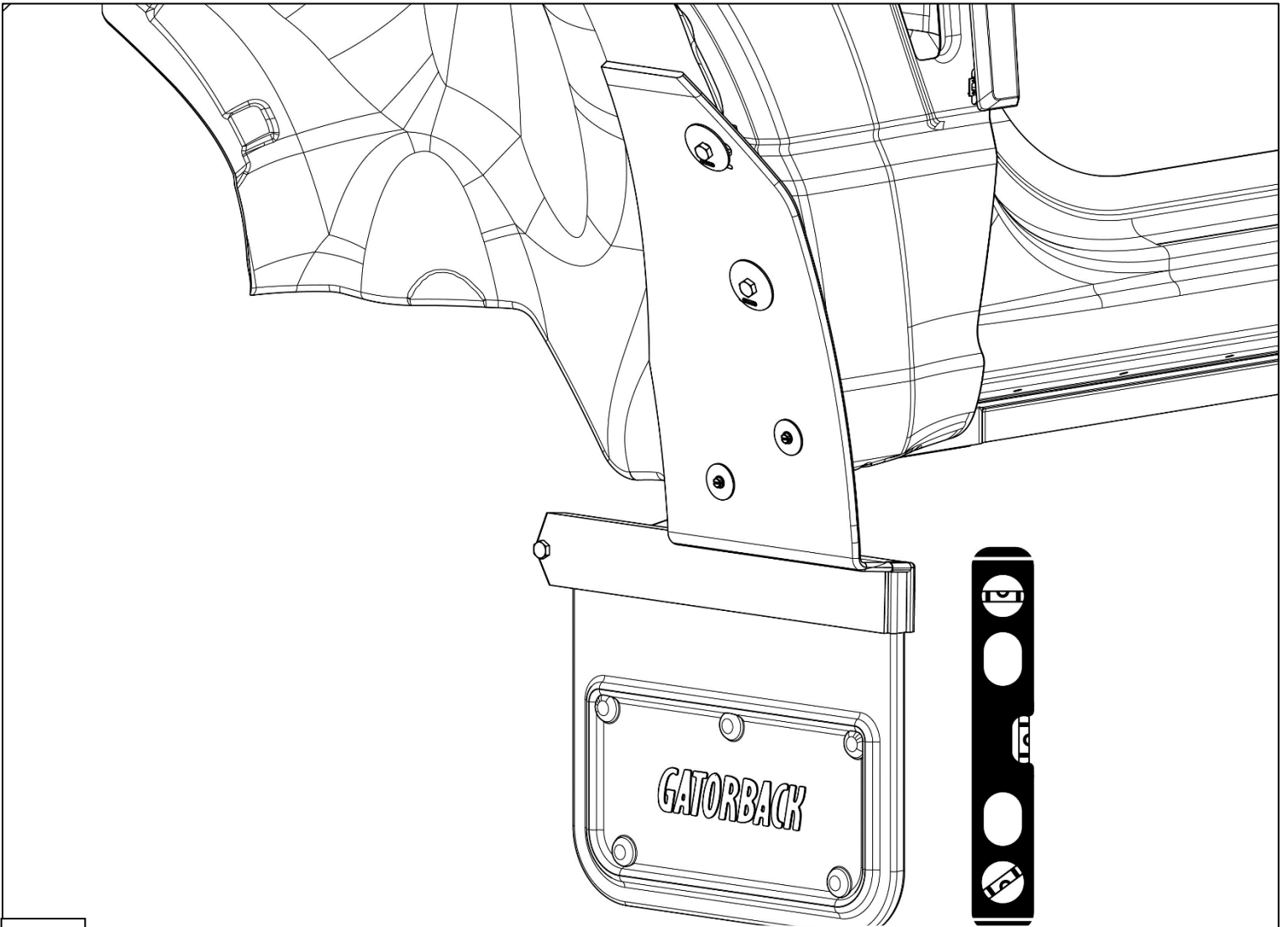

7-1 Use a level and visually determine your mud flap is straight. Gently tighten all fasteners.

### ASSEMBLY OF NYLON MUD FLAPS:

1. Remove locking caps from nylon upper mounts and set aside for reinstallation.
2. Remove and discard the plastic strip inside the track at the bottom of the nylon upper mount.
3. Slide rubber guide into track of nylon upper mount.
4. Reinstall locking cap(s) on bottom of nylon upper mount. Note: To fully lock this cap into place, you should hear two clicks. When the cap is fully locked, it will be even with the offset part of the upper mount.
5. Repeat Procedure for second mud flap.

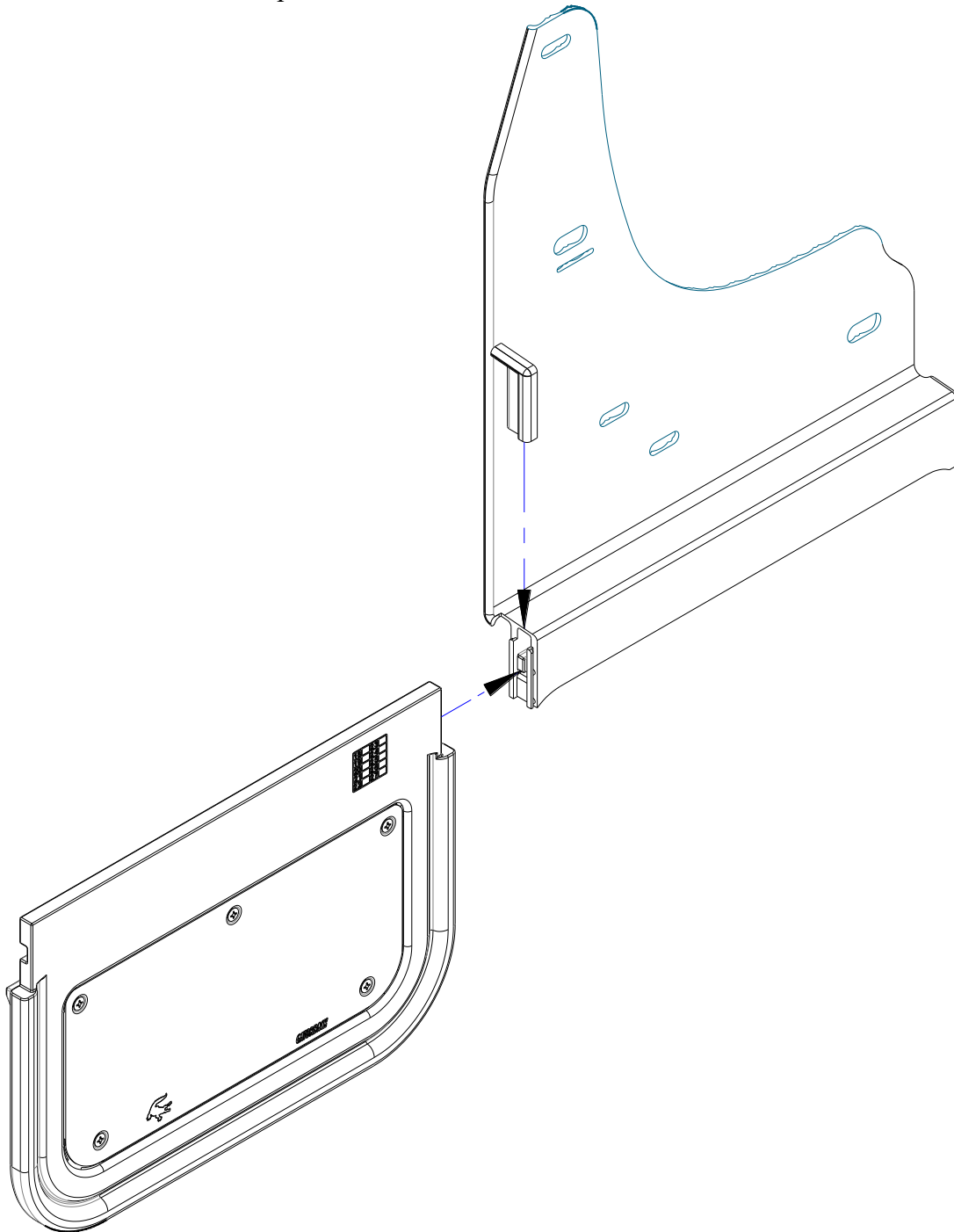

Please check out our YouTube channel to see an install video for this application.





**21-C Ford F-150**  
**Nylon Offset Mud Flap Set, Rear**  
**Mounting Diagram & Instructions**  
**GCN408R**

**IMPORTANT:**

**Manufacturer is not responsible for negligent use of vehicle with mud flaps installed, including over-tightening of screws and bolts causing damage to vehicle or mud flaps.**



**TOOLS REQUIRED-**



*Push Pin  
Removal Tool*

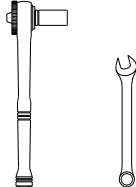

*7/16" Open Wrench  
and Socket Wrench*

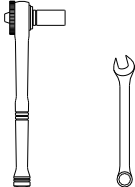

*3/8" Open Wrench  
or Socket Wrench*

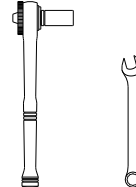

*5/16" Open Wrench  
or Socket Wrench*

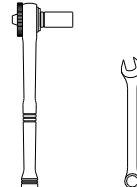

*1/4" Open Wrench  
or Socket Wrench*

**FLAPS AND BRACKETS**

*(1) Upper Mount  
Rear, Driver Side  
Part #771098*

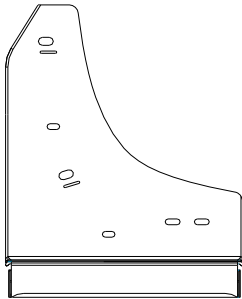

*(1) Upper Mount  
Rear, Passenger Side  
Part #771099*

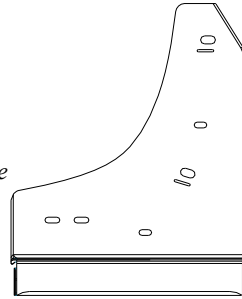

Please note: There will be a plastic piece in the upper mount channel. Please remove and discard.

*(2) Nylon Cap  
Driver Side  
Part #080642  
(Assembled on Upper Mount)*

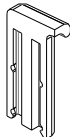

*(2) Nylon Cap  
Passenger Side  
Part #080643  
(Assembled on Upper Mount)*

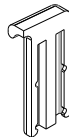

*(2) Rubber  
Universal  
12" x 10-3/4"*

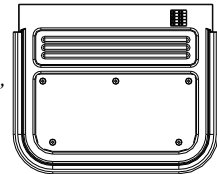

*(1) Bracket, Large  
Rear, Driver Side  
Part#769805*

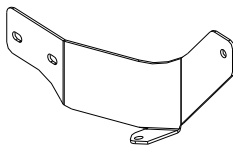

*(1) Bracket, Large  
Rear, Passenger Side  
Part#769806*

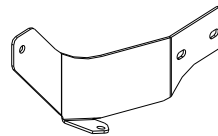

*(1) Bracket, Small  
Rear, Driver Side  
Part # 770946*



*(1) Bracket, Small  
Rear, Passenger Side  
Part #770947*

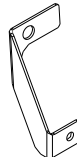

# PARTS BAG # 771103

**a)** (6) Machine Screw  
#10 x 1", Black Oxidized  
Part #012050

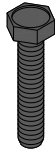

**b)** (4) Capscrew, Black Oxidized  
1/4"-20UNC x 5/8"  
Part #014071



**c)** (4) Capscrew, Black Oxidized  
1/4"-20UNC x 1"  
Part #014073

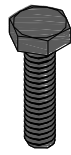

**d)** (2) Screw, Sheet Metal  
#8-18 x 1" Black Oxidized  
Part #016055



**e)** (6) Washer, Flat  
0.203" x 0.781", Stainless  
Part #018018

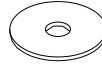

**f)** (2) Washer, Flat  
5/16" x 1" x 1/4" HDPE  
Part #018036



**g)** (4) Washer, Flat,  
0.281" x 1", SS, Blk Oxidized  
Part #018069

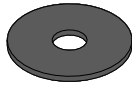

**h)** (8) Washer, Flat  
0.203" x 1" Black Oxidized  
Part #018070

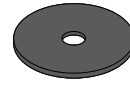

**i)** (6) Washer, Slotted  
0.281" x 1.5" Black Oxidized  
Part #018084



**k)** (2) Washer, lock  
1/4" Helicoil, Stainless  
Part #024000



**l)** (6) Washer, Lock  
1/8-8SS, #10, Stainless  
Part #024001



**m)** (2) Hex Nut  
1/4"-20, Stainless  
Part #025000

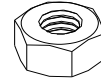

**n)** (6) Hex Nut  
#10-24, Stainless  
Part #025003



**o)** (2) Spring Nut  
#8, 9/16" Reach  
Part #028004



**p)** (2) Spring Nut  
1/4"-20UNC, 0.84" Reach  
Part #028010



**q)** (4) Washer, Nylon  
0.318" x 1" x 0.04"  
Part #054061

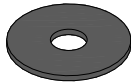

**r)** (6) Washer, Nylon  
0.203" x 0.885" x .062"  
Part #054080



**s)** (2) Mount Clip  
Driver Side  
Part #769308

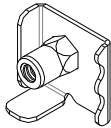

**t)** (2) Mount Clip  
Passenger Side  
Part #769309

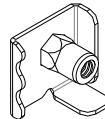



# INSTALLATION *(For ease of installation it is suggested that the wheel be removed)*

Note: Before you install your Mud Flap Set, see the diagram and parts list for all necessary parts.

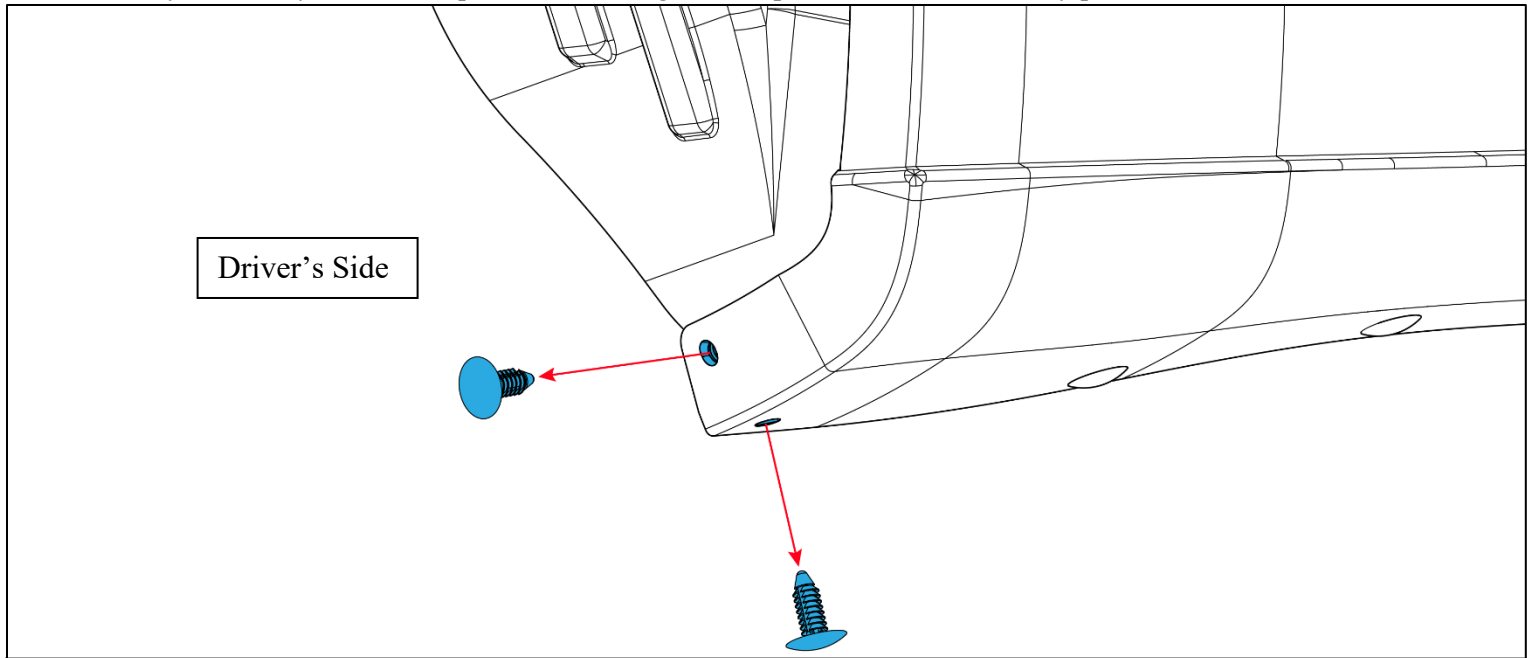

1-1 Remove factory hardware as shown.

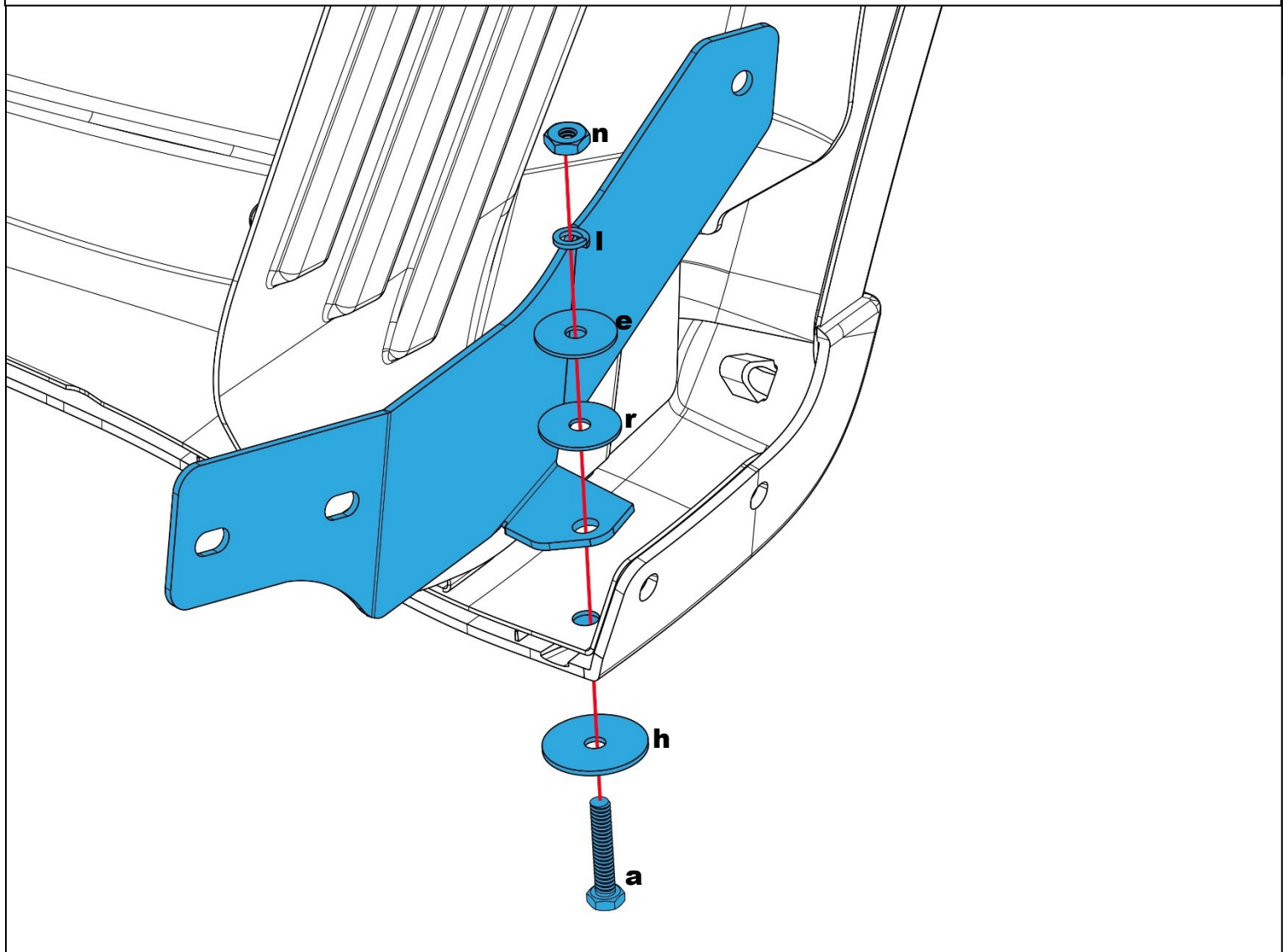

2-1 Loosely install bracket and hardware as shown.

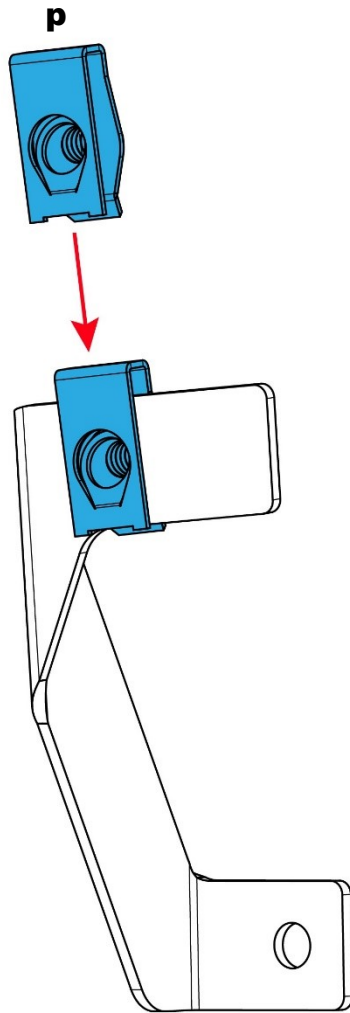

3-1 Install spring nut on bracket as shown.

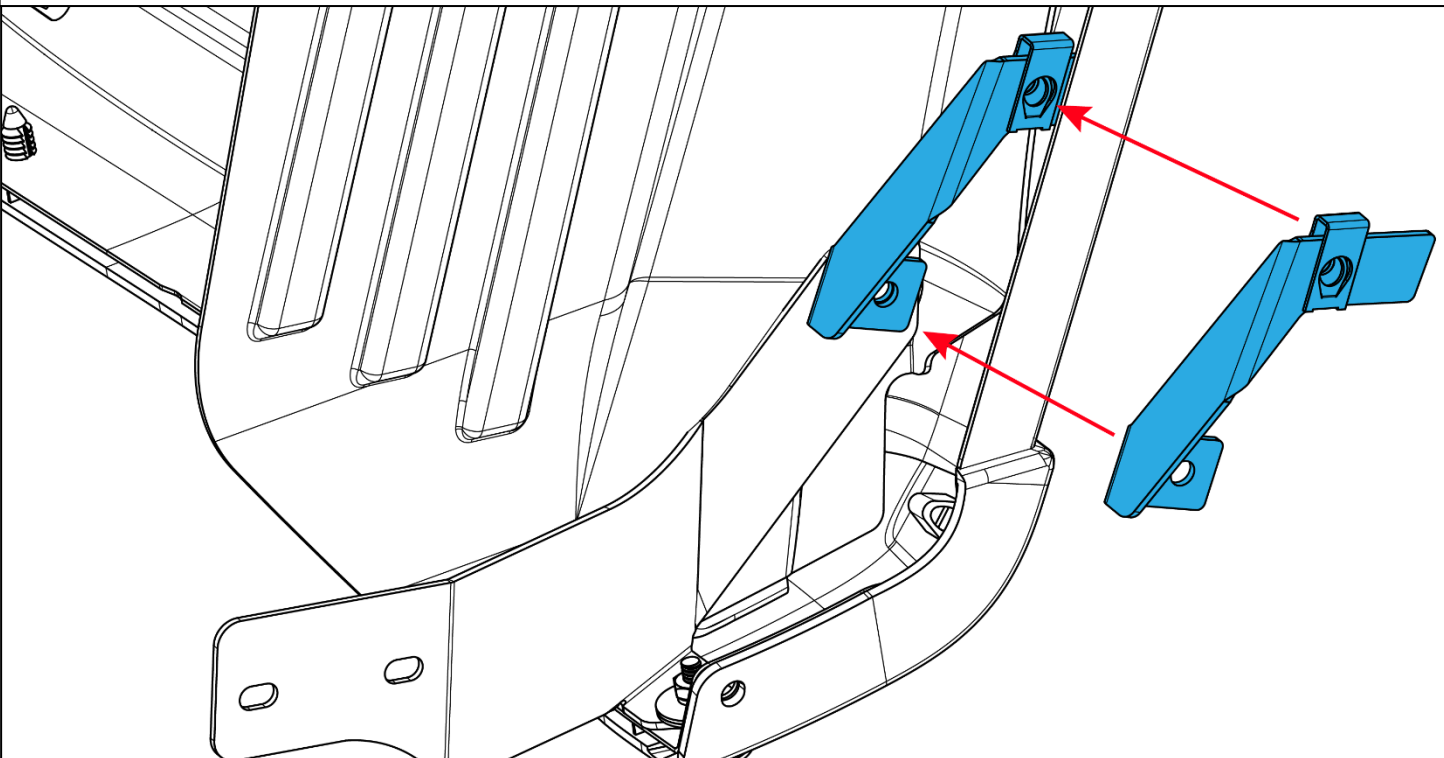

4-1 Ensure the small bracket is aligned so the edge of the top of the bracket is resting snugly against the sheet metal behind the wheel lip. Begin installing the small bracket to large bracket as shown in step 4-2.

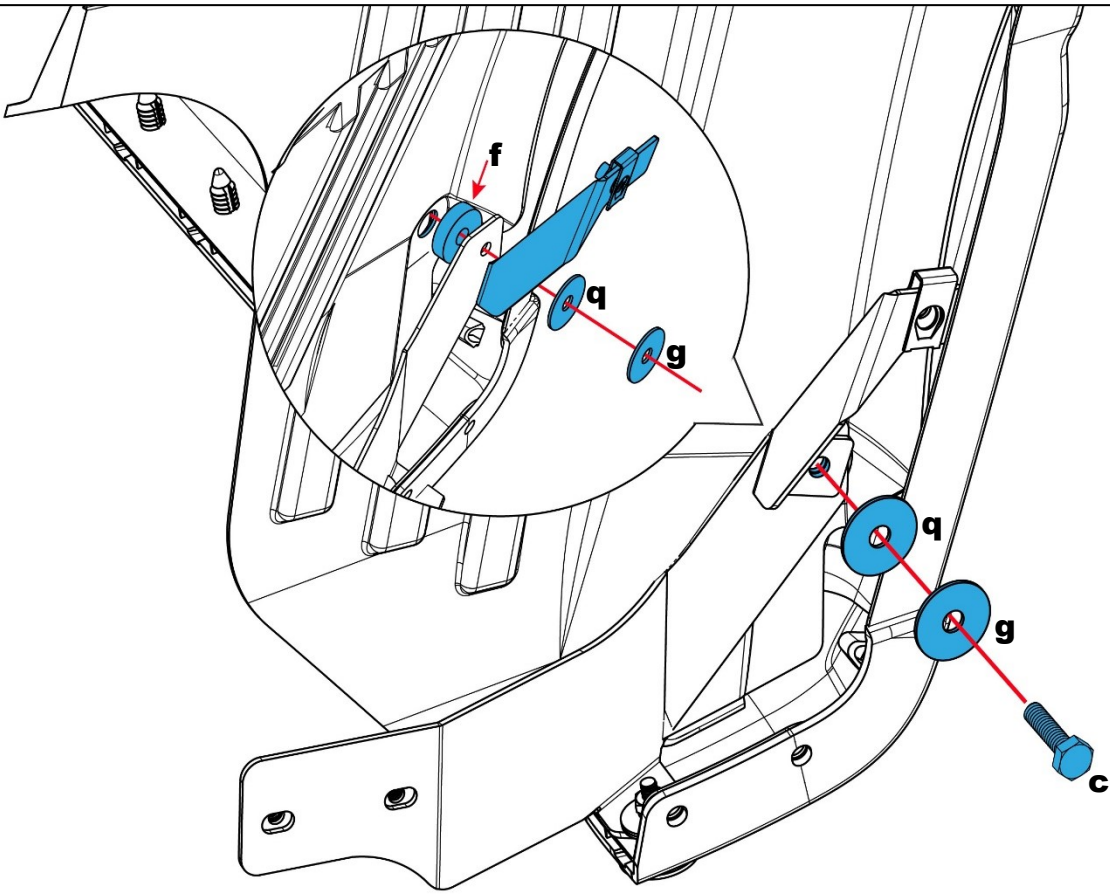

4-2 Install small bracket to large bracket as shown. Be sure to insert spacer (f) as shown before securing the bracket as shown in step 4-3.

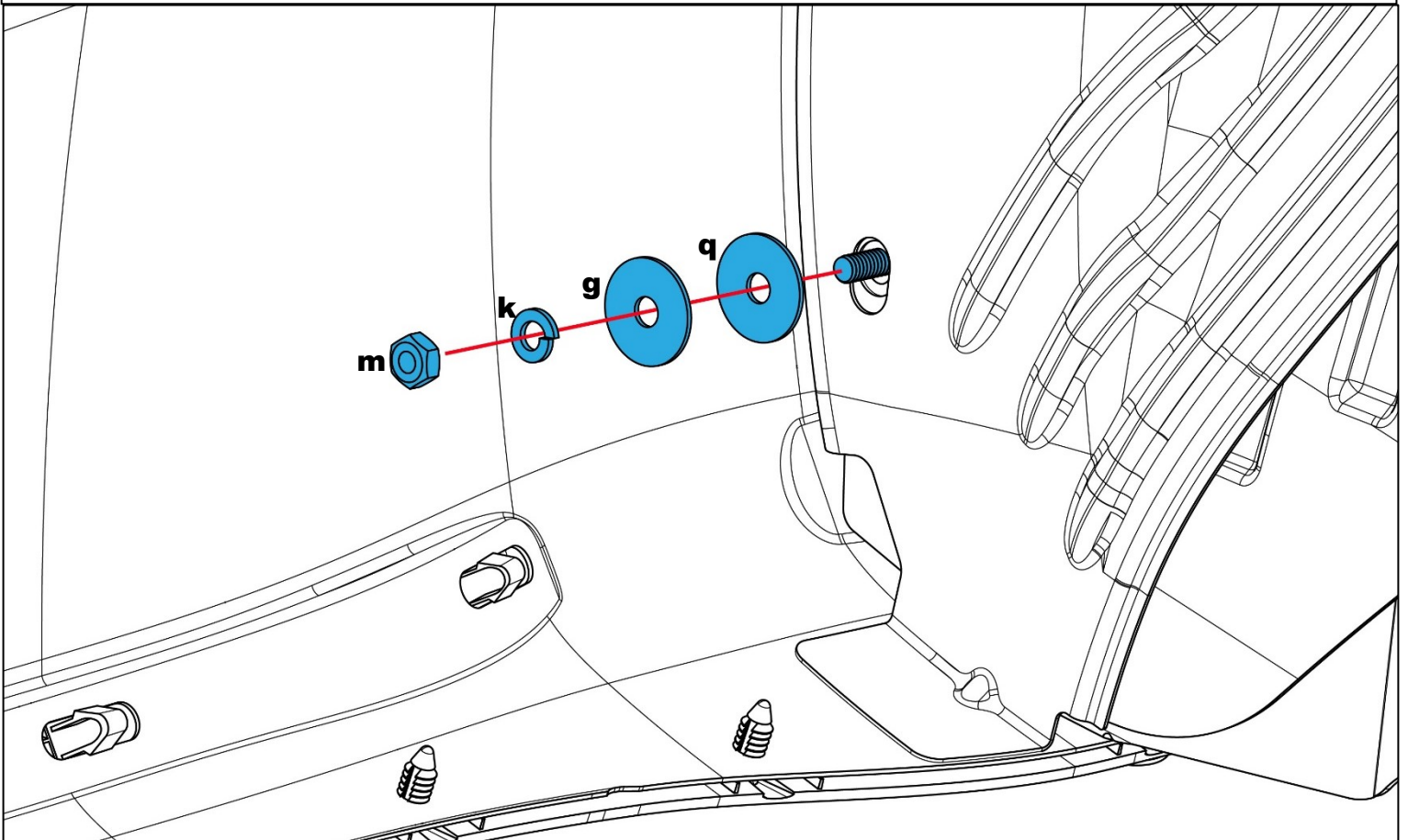

4-3 Secure hardware installed in step 4-2 as shown.

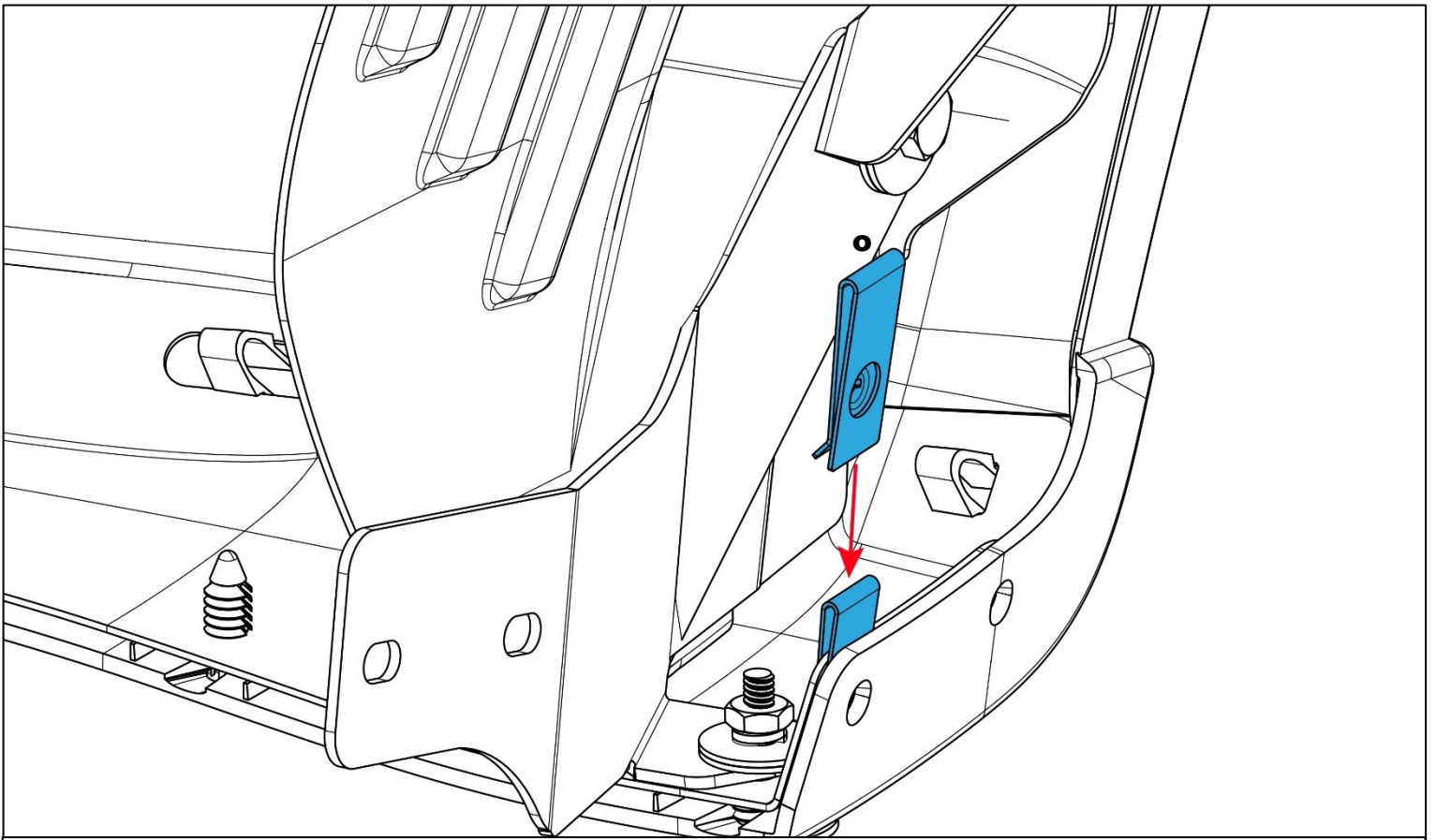

5-1 Install spring nut over factory hole on the sheet metal as shown.

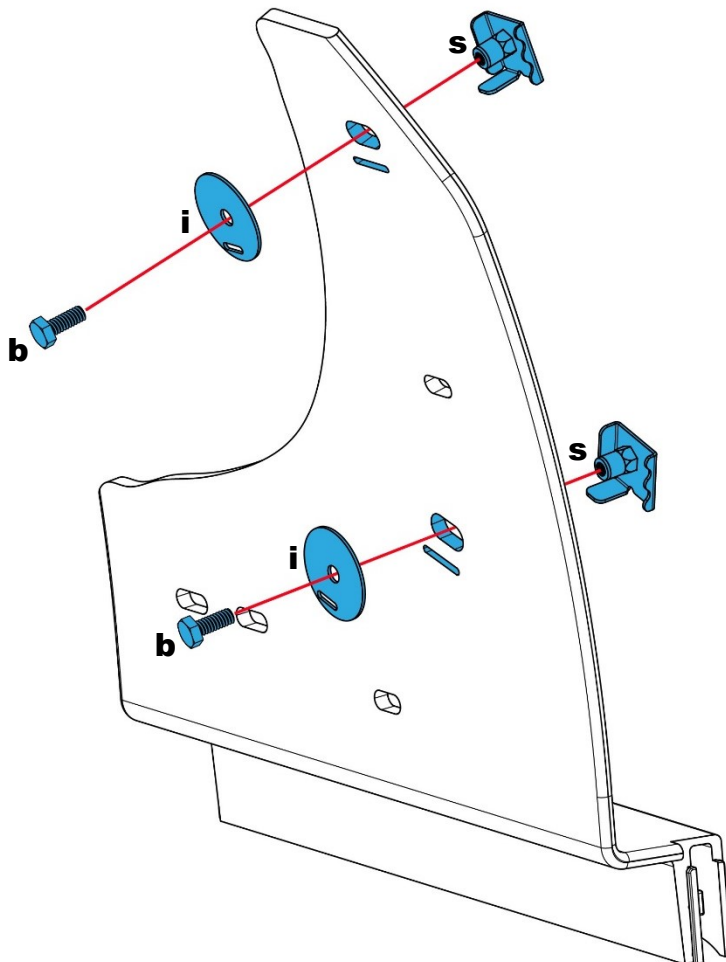

6-1 Loosely install mount clips on mud flap as shown.

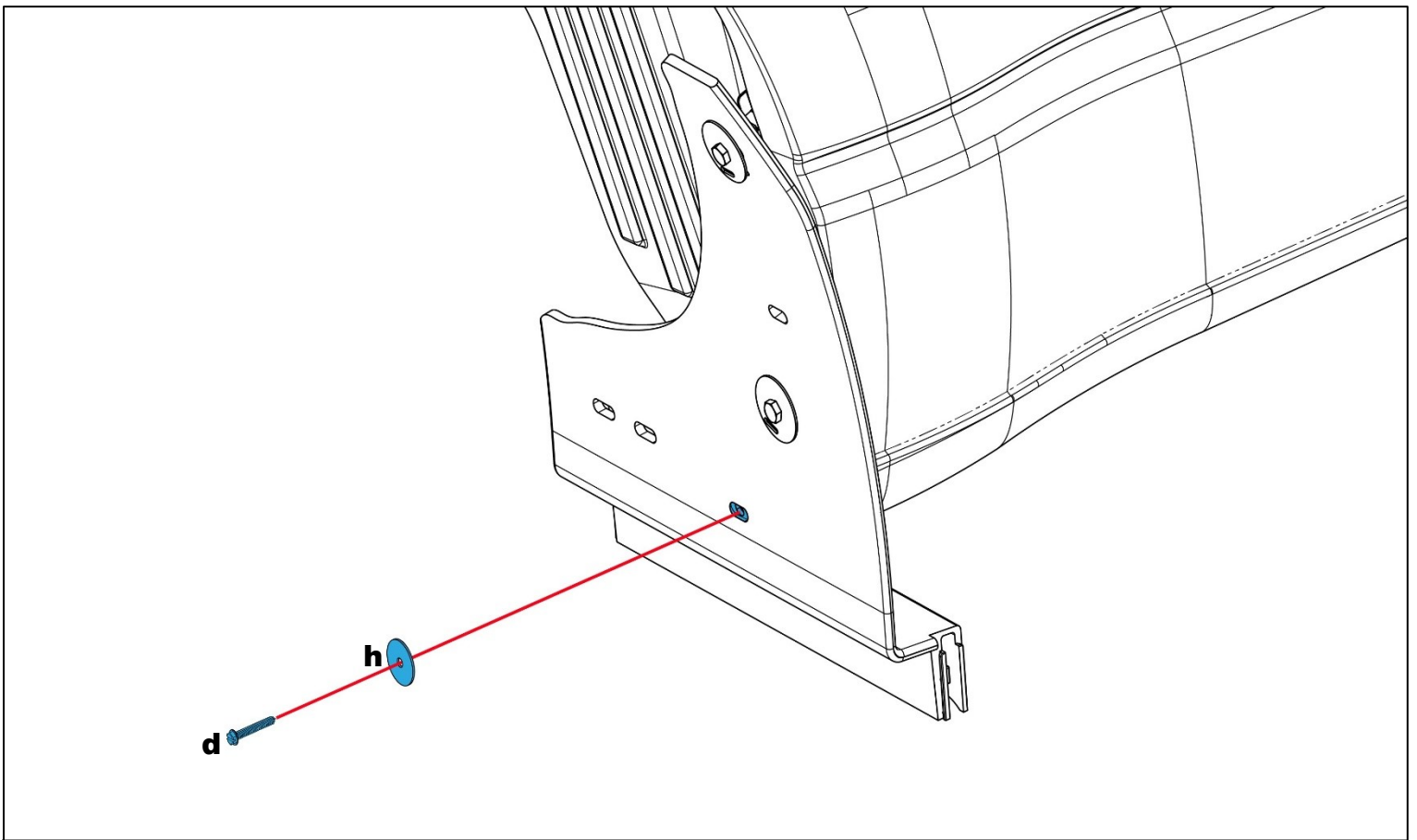

7-1 Loosely install hardware as shown.

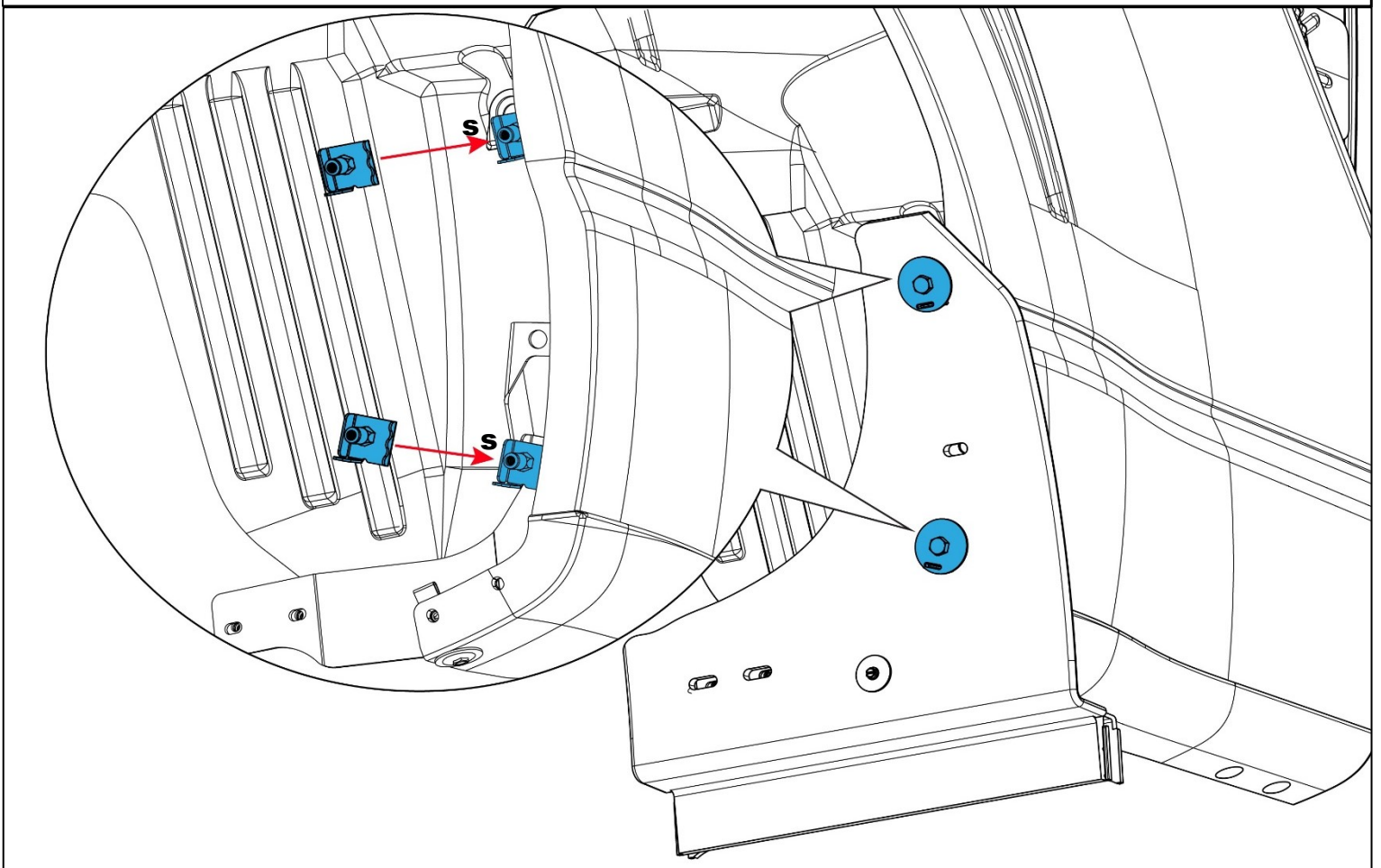

8-1 Slide mount clips behind fender lip as shown.

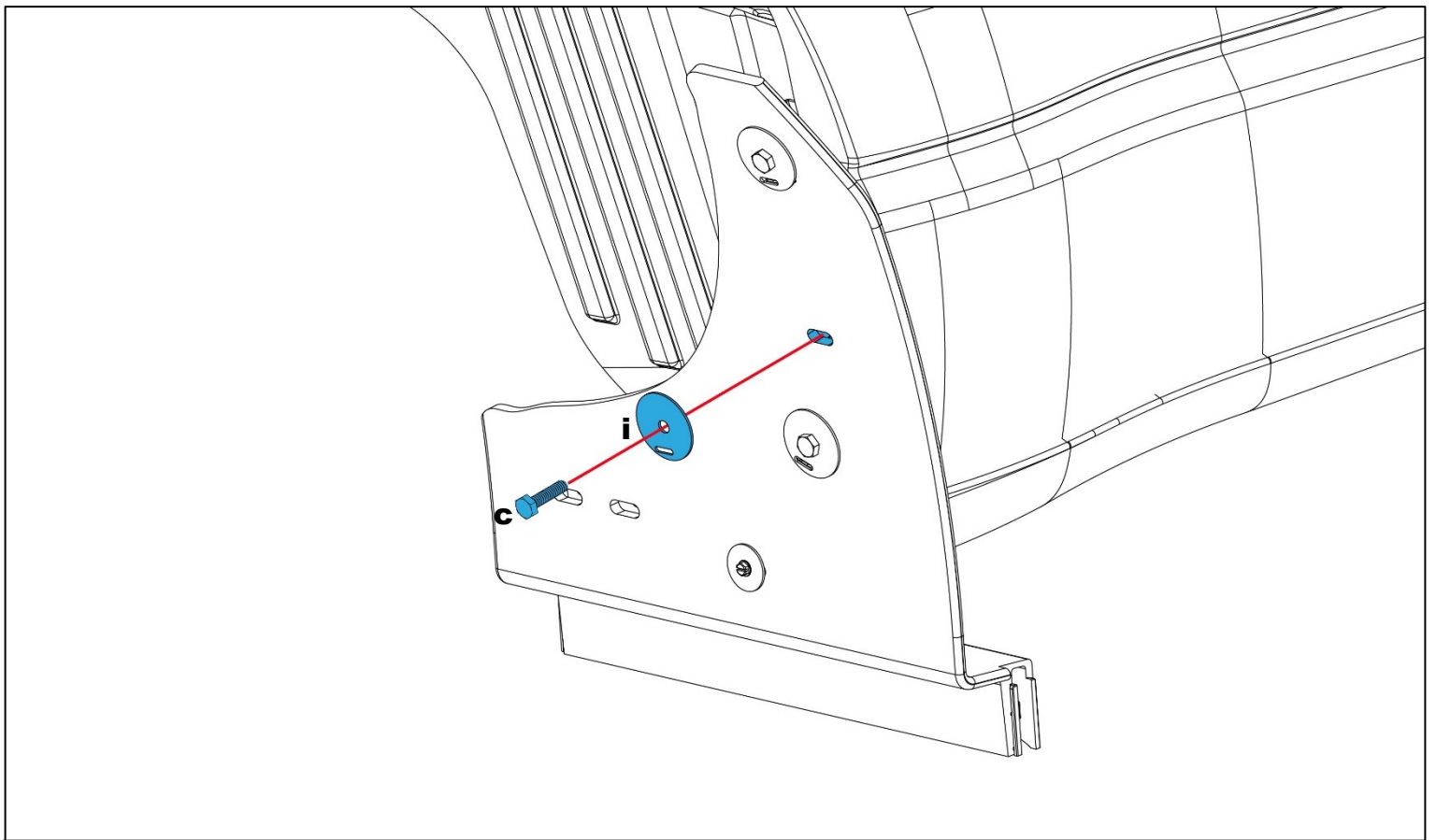

9-1 Loosely install hardware as shown.

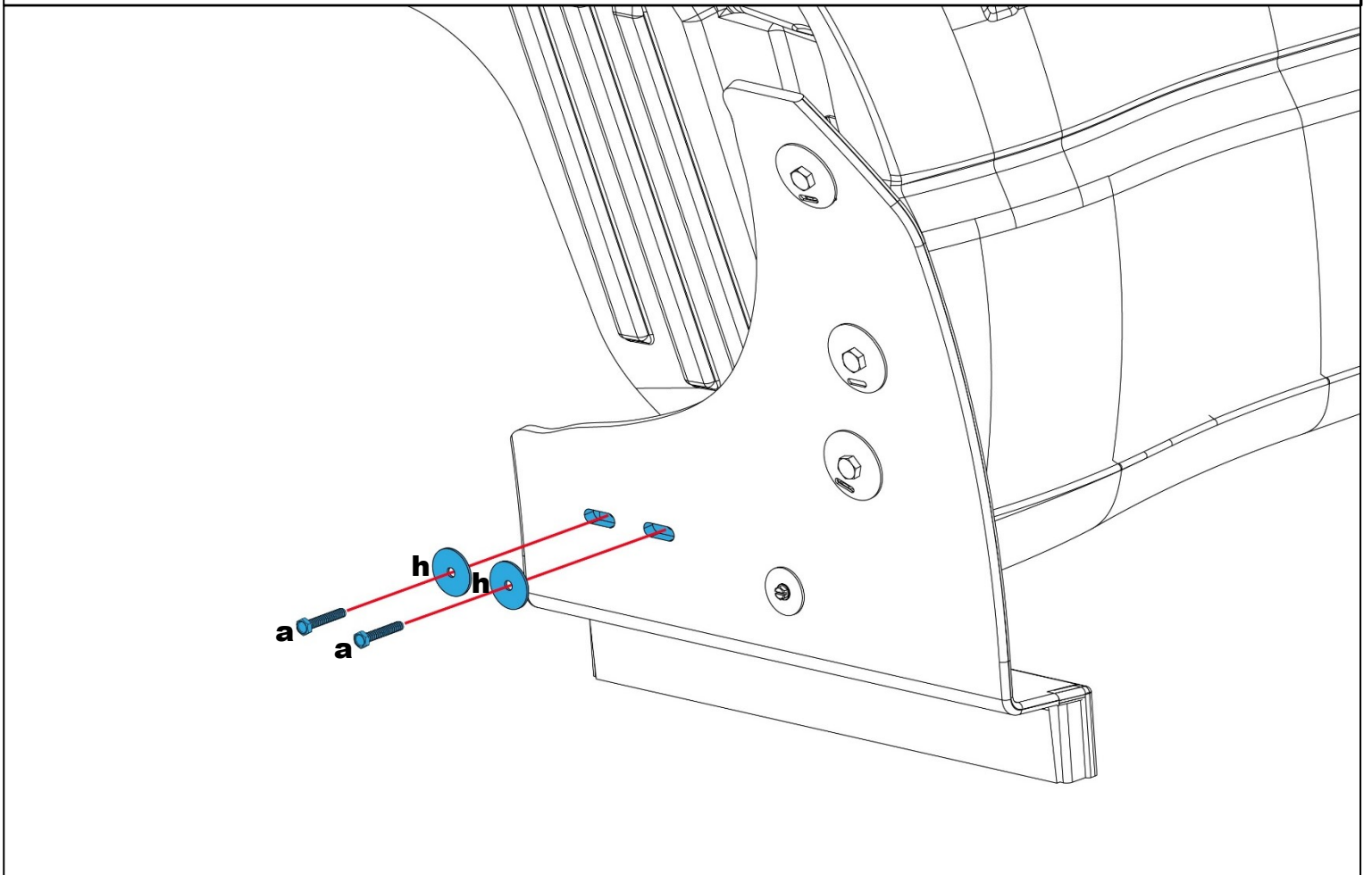

10-1 Loosely install hardware as shown as shown.

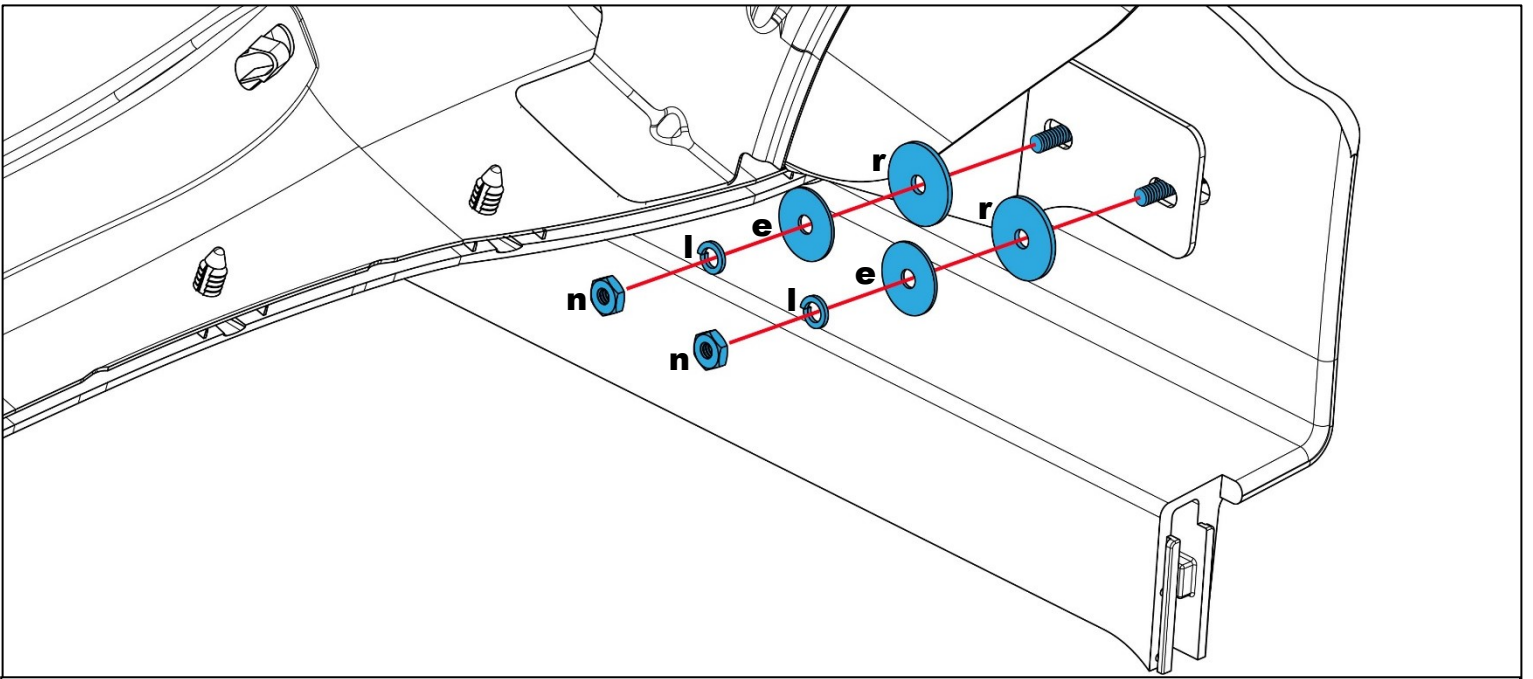

10-2 Loosely secure the hardware installed in step 10-1 as shown.

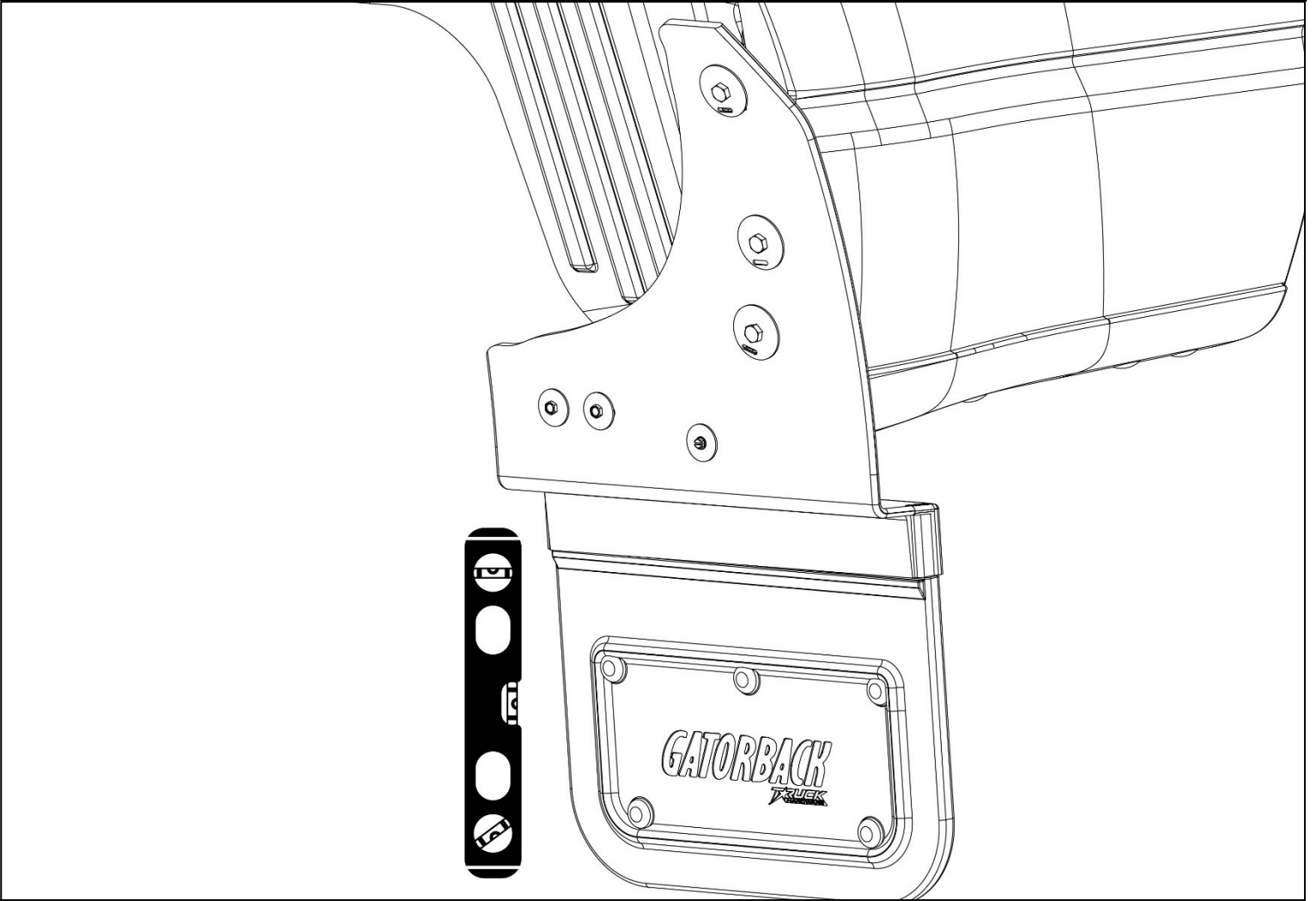

11-1 Use a level and visually determine your mud flap is straight. Gently tighten all fasteners.

## ASSEMBLY OF NYLON MUD FLAPS:

1. Remove locking caps from nylon upper mounts and set aside for reinstallation.
2. Remove and discard the plastic strip inside the track at the bottom of the nylon upper mount.
3. Slide rubber guide into track of nylon upper mount.
4. Reinstall locking cap(s) on bottom of nylon upper mount. Note: To fully lock this cap into place, you should hear two clicks. When the cap is fully locked, it will be even with the offset part of the upper mount.
5. Repeat Procedure for second mud flap.

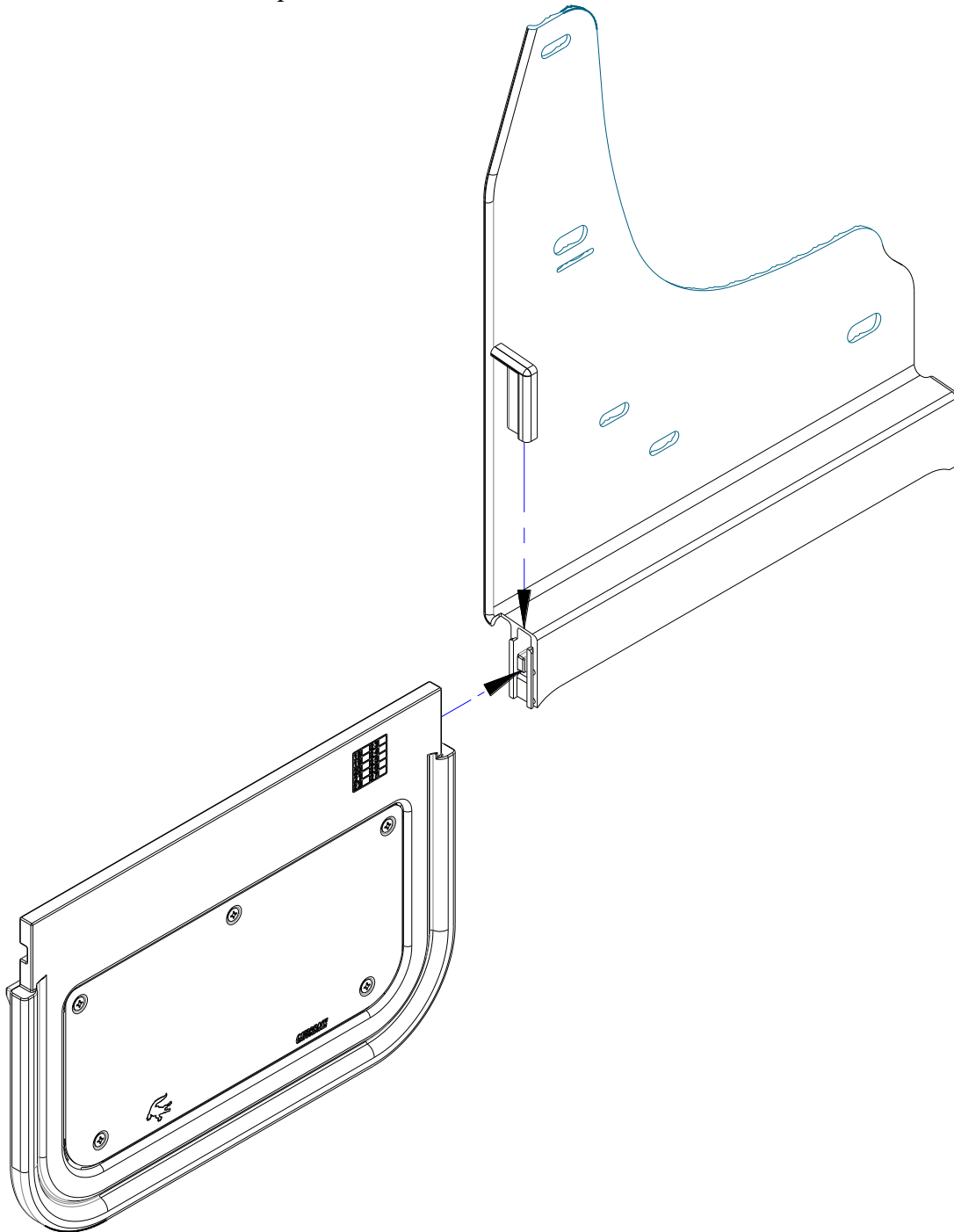

Please check out our YouTube channel to see an install video for this application.



1520 - 33 St N • Lethbridge, AB T1H 5H3 • Canada  
Toll free: 1-800-661-8208 • Email: info@truckhardware.ca • www.truckhardware.ca

