

IMPORTANT:

The manufacturer is not responsible for negligent use of vehicle with mud flaps installed, including over-tightening of screws and bolts causing damage to vehicle or mud flaps.

TOOLS REQUIRED:

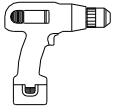

Electric or Chargeable
1/2" or 3/8" drill



5/16" Socket Driver

KIT CONTAINS: PARTS BAG #750309

a) (1) Flap Assembly,
Rear, LH
Part #755484

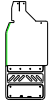

b) (1) Flap Assembly
Rear, RH
Part #755485



c) (14) Screw, TEK
#10-16 x 1"
Part #010009



d) (14) Flat Washer
0.203" x 1.0"
Part #018031



INSTALLATION: (For ease of installation, it is suggested that the wheel be removed)

1. Before you install your Mud Flap Set, see the Diagram and parts list for all necessary parts. Cut protective plastic and peel away from the stainless steel. Start on the Driver's Side.
2. Square the flap with the tire while holding the flap up against the wheel well, at the recommended height (approximately 8" from the bottom of the flap to the ground).
3. Locate the center of the wheel well or wheel flare on the back side of the stainless steel panel and drill four 1/4" holes from 'A' to 'D' on the stainless steel panel only.
4. Reposition the flap and ensure the 4 drilled holes on the stainless steel panel are centered on the wheel well.
5. Fasten the flap with 7 tek screws and washers on holes 'A' to 'D' & #1 to #3.
6. Repeat procedure for the passenger side.

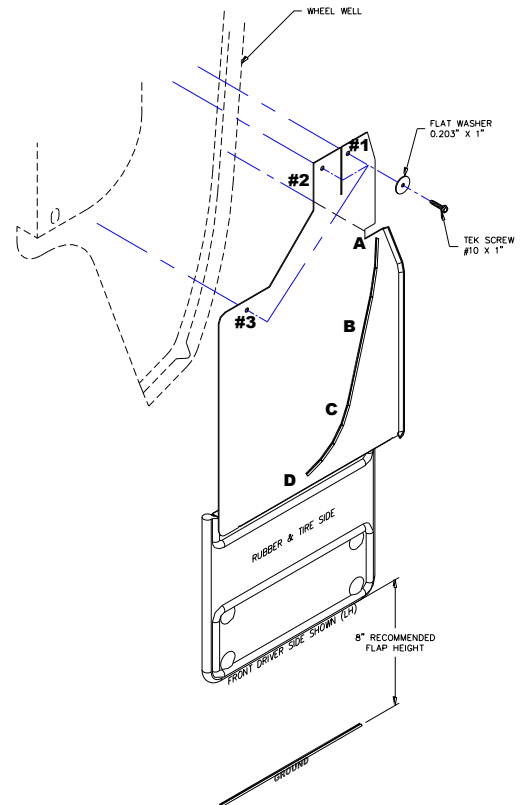
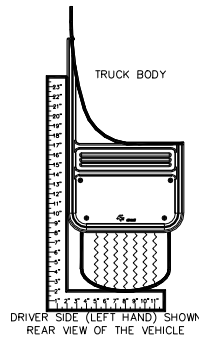

Note: Actual mounting will depend on individual truck equipment/accessories and personal preference.

IMPORTANT

Manufacturer is not responsible for negligent use of vehicle with Mud Flaps installed, or over tightening of screws and bolts causing damage to vehicle or mud flaps.