

**KIT INCLUDES:**

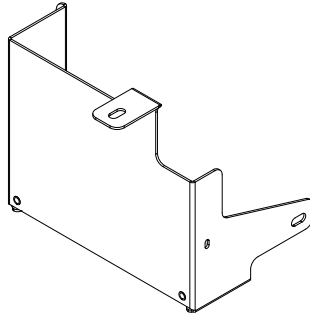

(1) Water Separator Guard  
Part#702349

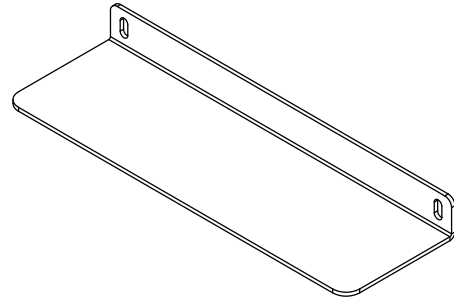

(1) Access Door  
Part #702350

**PARTS BAG: #702351**



a) (2) Capscrews, SS  
Part #014007

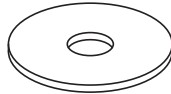

b) (2) Flat Washer, SS  
Part #018028

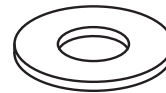

c) (1) Flat Washer, Pltd  
Part #018046

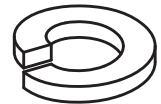

d) (2) Locking Washer, SS  
Part #024000



e) (1) Locking Washer, Pltd  
Part #024006



f) (1) Hex Nut, Pltd  
Part #025015

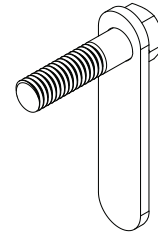

g) (1) Universal T-bolt,  
Part #762236

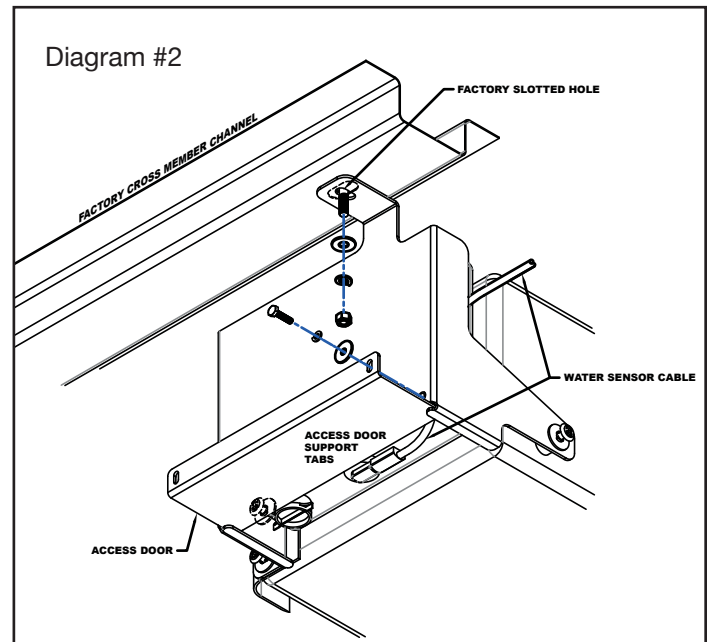
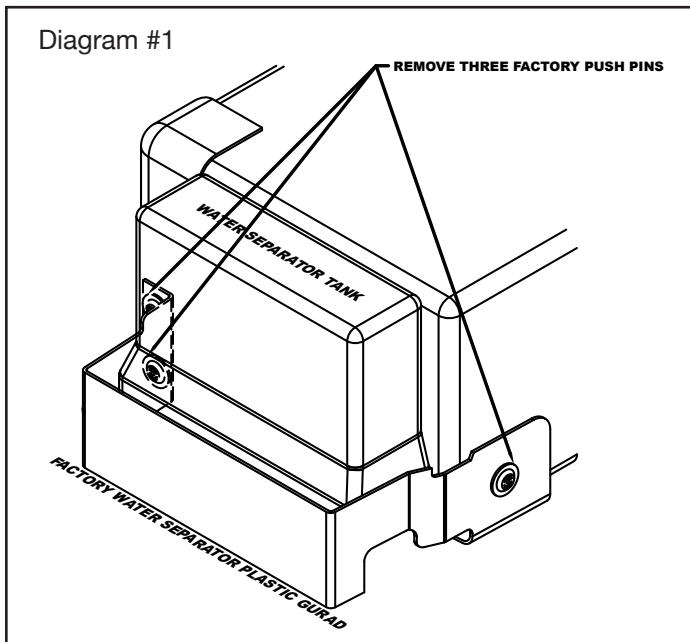

## INSTALLATION INSTRUCTIONS

1. Before you install your water separator guard, see the diagram and parts list for all necessary parts.
2. Remove the three factory push pins to remove the plastic factory guard from the water separator tank & discard. Keep the white factory push pins for later re-installation.

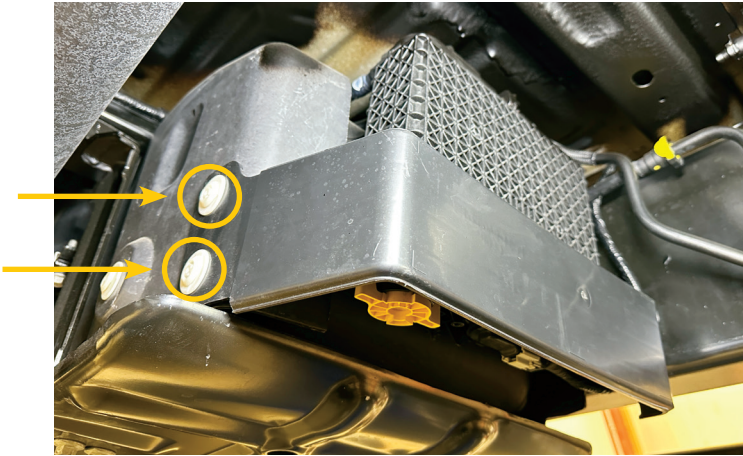

3. Remove Water Separator Sensor Mount clip from the driver side frame.



4. Install the T-bolt in the factory slotted hole on the cross member channel with the bolt facing downward.

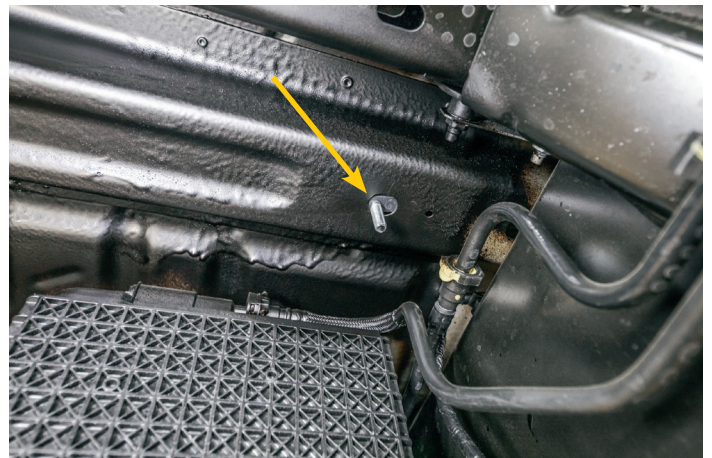

5. Start to install the Water Separator Guard, ensuring the sensor cable is placed inside the guard.

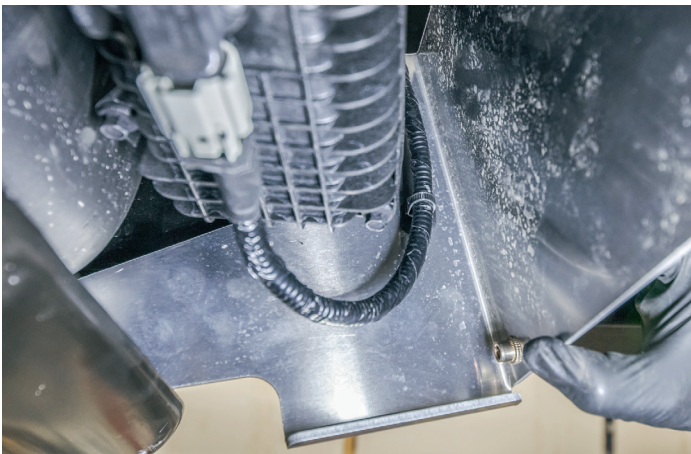

6. Carefully place the slotted hole on the upper mount tab of the guard to the T-bolt & loosely fasten with Flat Washer (c), Lock Washer (e) & Hex Nut (f).

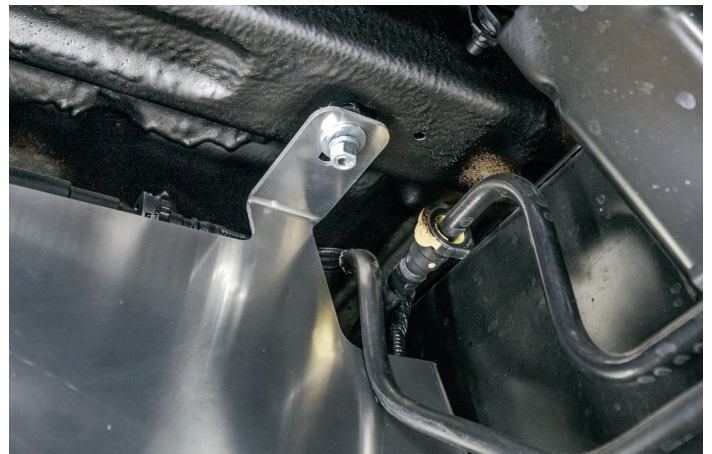

7. Use the previously removed factory push pins & secure the guard in the same way the factory guard was secured.



8. Now that the guard is secure, tighten the hex bolt on the T-bolt.

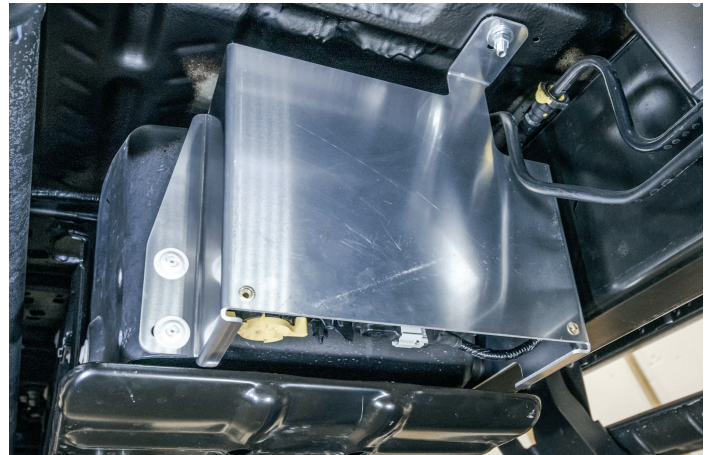

9. Finally, slide the access door between the two support tabs on the bottom of the guard, then bolt the access door using 2x washers (b), 2x lock washers (d) & 2x cap screws (a)

