



GATORBACK MUDFLAPS

21-C Ford Bronco Sport Mud Flap Set, Front Mounting Diagram & Instructions

IMPORTANT:

Manufacturer is not responsible for negligent use of vehicle with mud flaps installed, including over-tightening of screws and bolts causing damage to vehicle or mud flaps.

TOOLS REQUIRED-



Push Pin Removal Tool

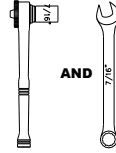

7/16" Open Wrench
and Socket Wrench

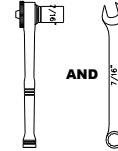

1/4" Open Wrench
and Socket Wrench

FLAPS AND BRACKETS

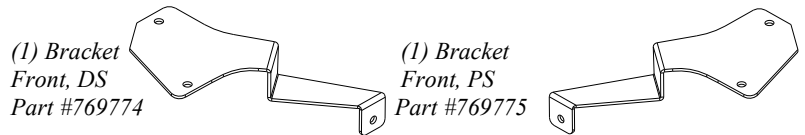
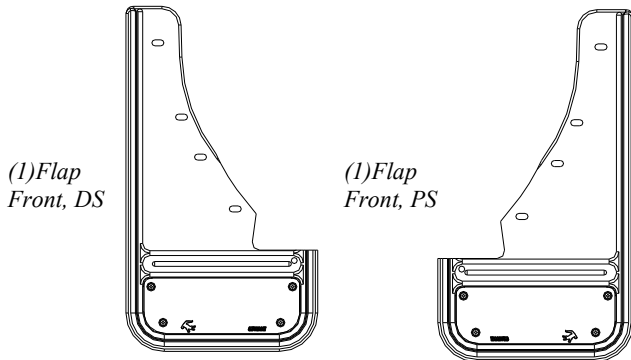

PARTS BAG # 769776

a) (6) Capscrew, Blk Oxid.
SS, 1/4-20UNC x 3/8"
Part #014069



b) (2) Capscrew, Blk Oxid.
SS, 1/4"-20UNC x 1"
Part #014073



c) (4) Screw, Sht Mtl
#8-18 x 1" SS
Part #016054



d) (2) Screw, Sht Mtl.
#8-18 x 1" Blk Ox.
Part #016055



e) (2) Washer, Flat,
0.281" x 1", SS, Blk Ox.
Part #018069

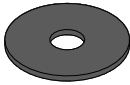

f) (6) Washer, Offset
0.281" x 1.5", Blk Ox.
Part #018087



g) (2) Washer, Flat
0.203" x 1" Blk Ox.
Part #018070

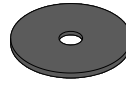

h) (2) Washer, Flat
0.203" x 1", SS
Part #018031

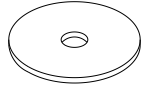

i) (2) Washer, Half
0.203" x 1", SS
Part #018032

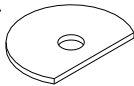

j) (4) Washer, Flat
0.281" x 1", SS
Part #018028

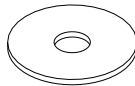

k) (4) Hex Nut
1/4"-20, SS
Part #025000



l) (4) Washer, lock
1/4" » Helicoil, SS
Part #024000



n) (4) Washer, lock
#18-8, 10 Helicoil, SS
Part #024001



p) (8) Spring Nut
1/4"-20UNC, 0.84" Reach
Part #028011



q) (2) Clip
Short
Part #769799

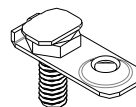

r) (2) Clip
Long
Part #769801

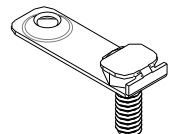

INSTALLATION *(For ease of installation it is suggested that the wheel be removed)*

1. Before you install your Mud Flap Set, see the diagram and parts list for all necessary parts.
2. On the underside of the vehicle, install the short clip (p) on the oblong factory hole #1 closest to the front of the vehicle, securing with a flat half washer (i), lock washer (m), and screw (c) and the long clip (q) on the oblong factory hole #2 closest to the back of the vehicle, using a flat washer (h), lock washer (m), and screw (c). (See Diagram 1)

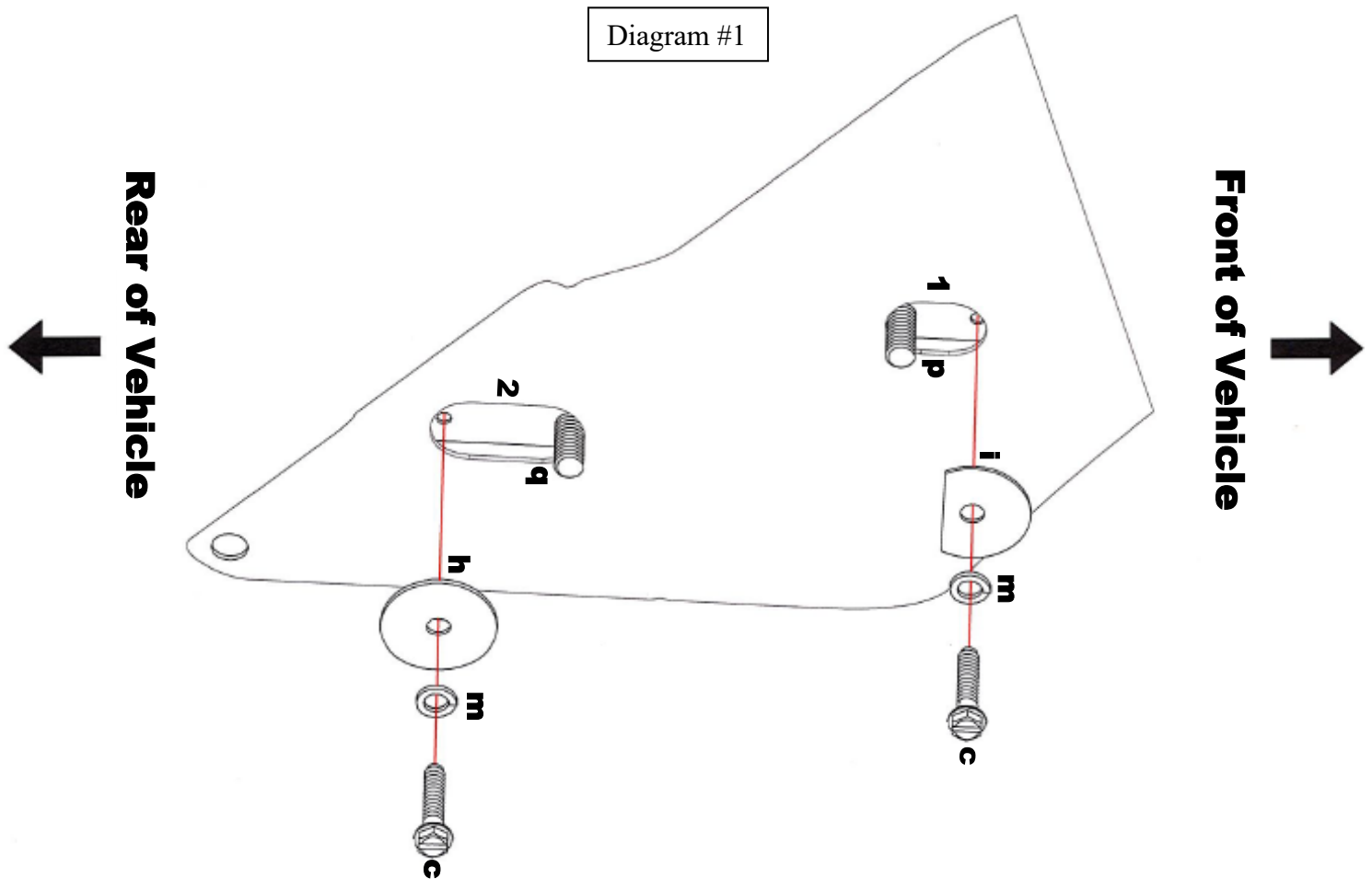

Note: If you would like to see how to install our custom clips, please see our YouTube Channel

3. Install the bracket through holes #3 & #4 to previously installed clips on holes #1 & #2, securing with a flat washer (j), lock washer (l), and hex nut (k). (See Diagram 2)

Diagram #2

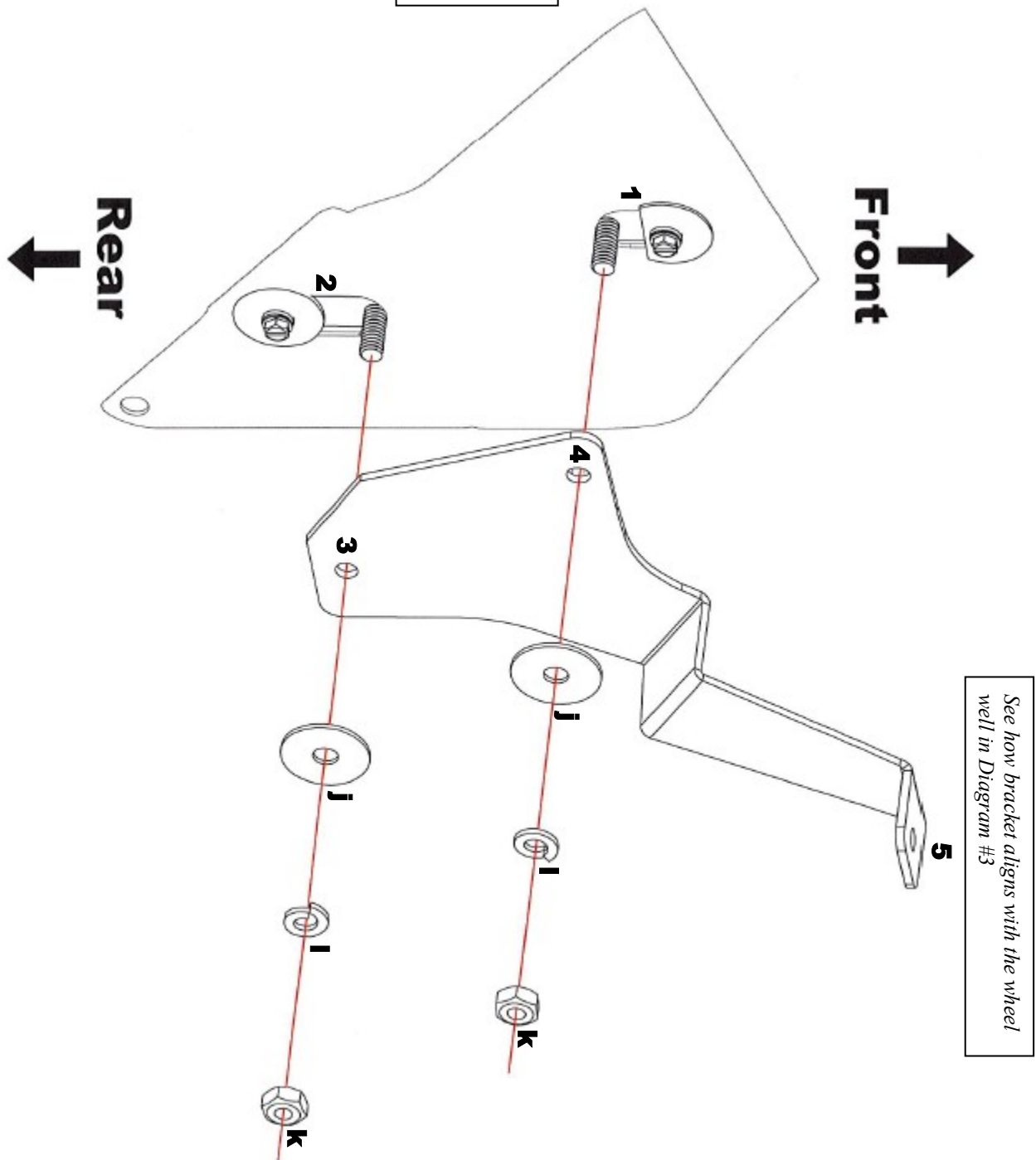

4. Remove the factory push pin from hole #6 and discard.
5. Install spring nut (n) on fender lip factory hole #6 with the extruding end facing in.
6. Loosely install mud flap through hole #8 to through spring nut (n) to factory hole #6 using an offset washer (f) and capscrew (b)
7. Line mud flap up with fender lip and mark fender lip with a pen through mud flap holes #9 to #11.
8. Install spring nuts (n) on fender lip on each marked position with the extruding end facing out.
9. Install mud flap hole #9 to spring nut (n) using an offset washer (f) and capscrew (a)
10. Install mud flap hole #10 to spring nut (n) using a flat washer (e) and cap screw (a)
11. Install mud flap hole #11 to spring nut (n) using a flat washer (f) and cap screw (a)
12. Install mud flap hole #7 to bracket hole #5 using a flat washer (g) and screw (d)

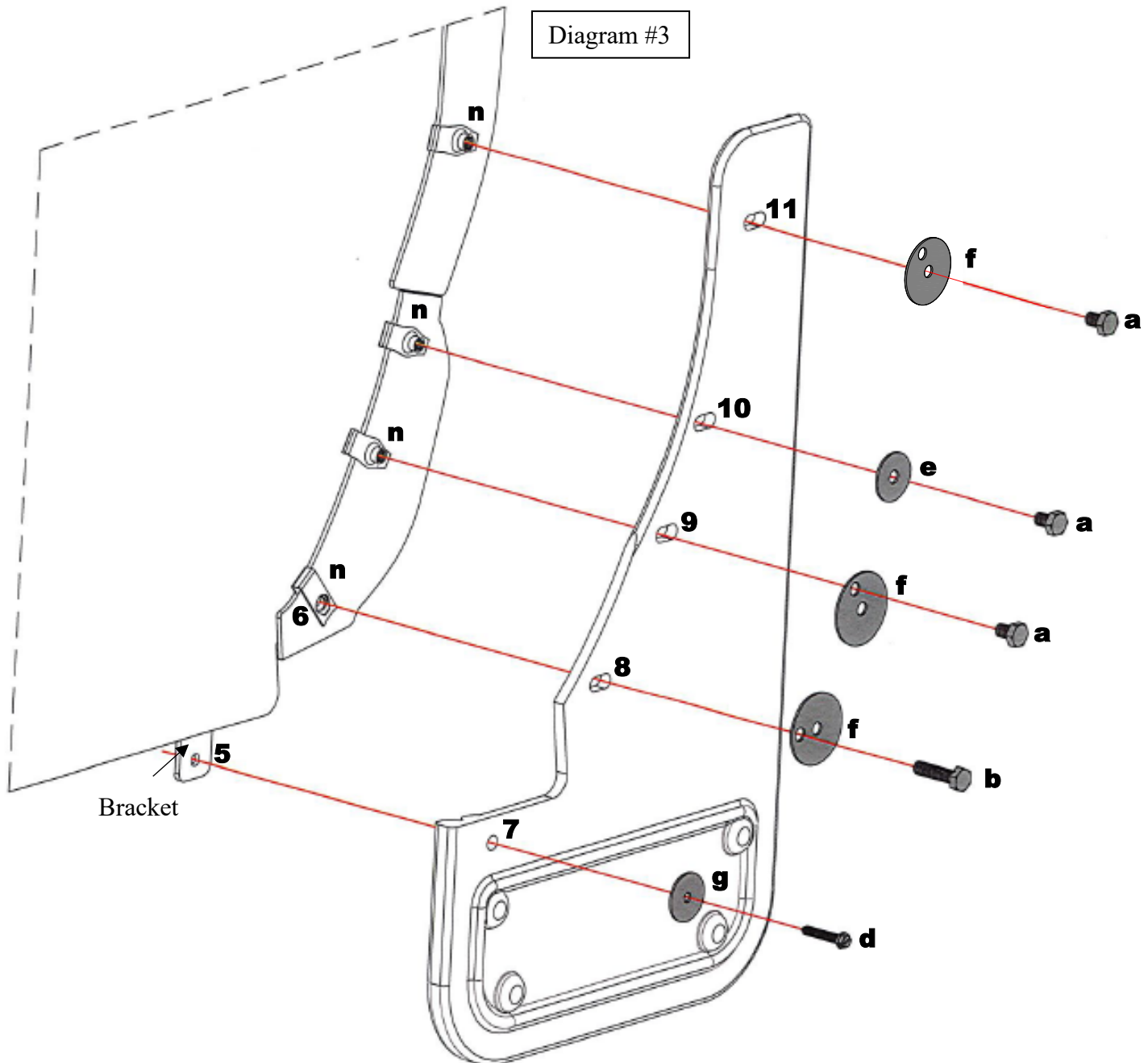

Please check out our YouTube channel to see an install video for this application.





GATORBACK MUDFLAPS

2021-C Ford Bronco Sport Mud Flap Set, Rear Mounting Diagram & Instructions GCR405R

IMPORTANT:

Manufacturer is not responsible for negligent use of vehicle with mud flaps installed, including over-tightening of screws and bolts causing damage to vehicle or mud flaps.

TOOLS REQUIRED-



Push Pin Removal Tool

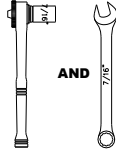

7/16" Open Wrench
and Socket Wrench

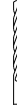

1/4" Drill Bit

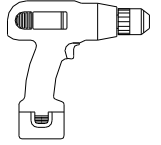

Electric or
Rechargeable Drill

FLAPS AND BRACKETS

(1) Flap
Front, DS

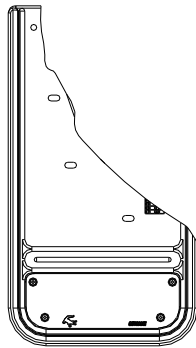

(1) Flap
Front, PS

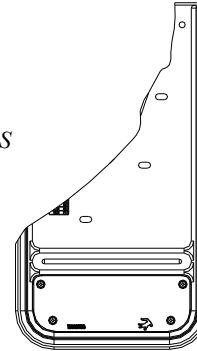

PARTS BAG # 769777

a) (2) Capscrew, Blk Oxidized
SS, 1/4"-20UNC x 3/8"
Part #014069



b) (6) Capscrew, Blk Oxidized
SS, 1/4"-20UNC x 1"
Part #014073

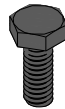

c) (8) Spring Nut
1/4"-20UNC, 0.54" Reach
Part #028010



d) (6) Washer, Flat,
1"OD, SS, Blk Ox.
Part #018069

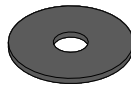

e) (2) Washer, Offset
0.281" x 1.5", SS
Part #018087



INSTALLATION *(For ease of installation it is suggested that the wheel be removed)*

2. Before you install your Mud Flap Set, see the diagram and parts list for all necessary parts.
3. Remove the (4) lowest factory push pins on the fender lip. Set 1 aside for reinstallation and discard the remaining 3.
4. Pull back fabric liner and install spring nuts (c) on factory holes #1 to #3 with the extruding end facing in. (See Diagram #1).
4. Loosely install mud flap holes #7 & #8 to factory holes #2 & #3 through spring nuts (c) using a capscrew (b) and flat washer (d).
5. Line mud flap hole #9 up with the fabric liner and mark the spot using a marker. Using a 1/4" drill bit, drill a small hole (#4) in the liner in that location. Gently pull back the liner and install a spring nut (c) on fender lip, lining it up with the hole in the fabric liner with the extruding end facing out. Put the liner back in place and reinstall the previously removed factory push pin into hole #5.
6. Loosely install mud flap hole #9 to spring nut (c) using a capscrew (a) and flat washer (d)
7. Loosely install mud flap hole #6 to factory hole #1 through spring nut (c) using a capscrew (b) and offset washer (e) installing the capscrew through the outer hole of the washer.
8. Before tightening, check that the flap is straight and level using a square or bubble level. (Do not over tighten)
9. Repeat procedure for the passenger side.

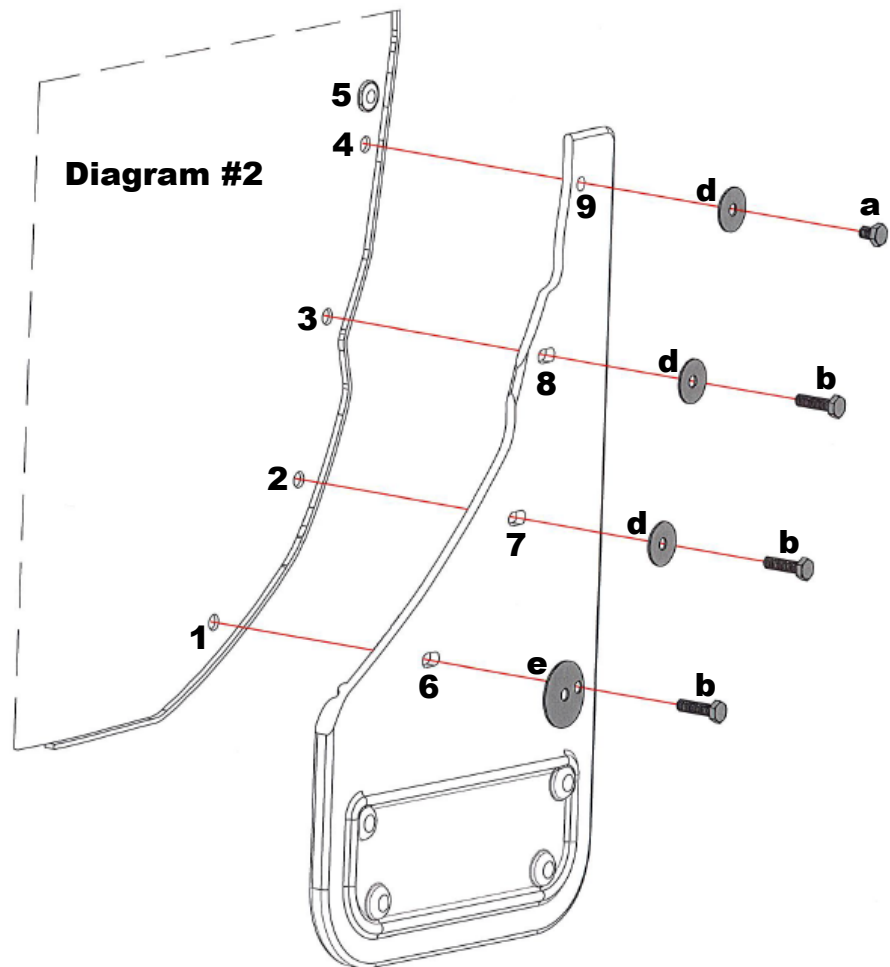
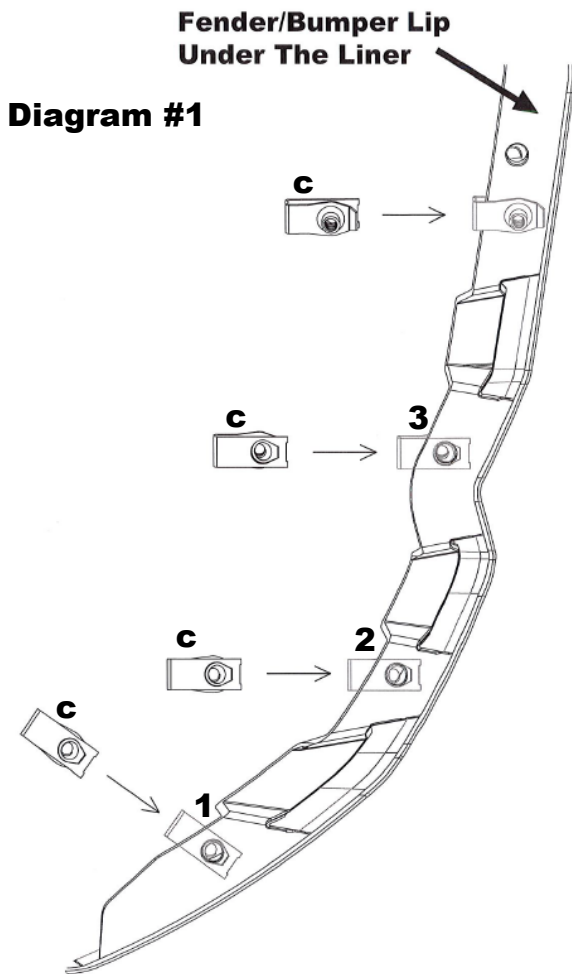

Please check out our YouTube channel to see an install video for this application.

