



2020 Escape Mud Flap Set, Front Mounting Diagram & Instructions GCR404F

IMPORTANT:

Manufacturer is not responsible for negligent use of vehicle with mud flaps installed, including over-tightening of screws and bolts causing damage to vehicle or mud flaps.



TOOLS REQUIRED-

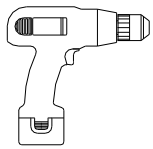

Electric or Rechargeable
Drill

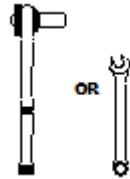

5/16" Open Wrench or
Socket Wrench

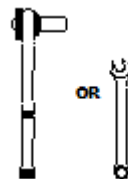

3/8" Open Wrench or
Socket Wrench



Push Pin
Removal Tool

FLAPS

(1) Flap Assembly,
Front, DS

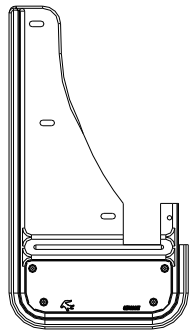

(1) Flap Assembly
Front, PS

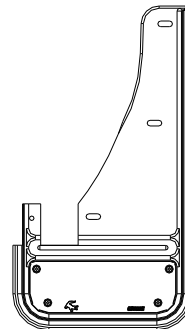

PARTS BAG #768531

a) (2) Washer, Flat
0.203" x 1", Blk Oxid.
Part #018070

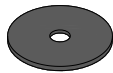

b) (4) Washer, Flat
0.203" x 1.5", Blk Oxid.
Part # 018072

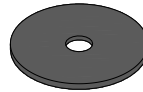

c) (2) Washer, Flat
0.203" x 0.781" SS
Part # 018018



d) (2) Washer, Offset
0.281" x 1.5", Blk Ox
Part #018080

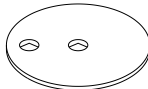

e) (2) Screw, Machine
18-SS, 10-24x1, Hex Hd
Part #012022

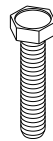

f) (6) SS Bolt, Hex Flange
M4.2 x 1", Black
Part # 016041

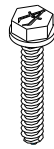

g) (2) Washer, Lock
18-8SS, Helicoil
Part #024001



h) (2) Nut, Hex
#10-24, SS
Part #025003



i) (6) Spring Nut
#8, 9/16" Reach
Part #028004



INSTALLATION (For ease of installation it is suggested that the wheel be removed)

1. Before you install your Mud Flap Set, see the diagram and parts list for all necessary parts. Start on the driver's side.
2. Remove the 3 factory push pins from the inner fender well on holes #1 to #3.
3. Gently pull the liner away to install spring nuts (i) on recessed factory tabs, which previously contained the factory push pins.



4. Loosely install mud flap holes #4 & #5 to factory holes #1 & #2 through spring nuts (i) using a stainless steel bolt (f) and flat washer (b)
5. Loosely install mud flap hole #6 to factory hole #3 through spring nut (i) using a stainless steel bolt (f) and an offset washer (d)
6. Using a square or bubble level, ensure that the mud flap is level. Tighten all fasteners.
7. Drill a ¼" hole through mud flap hole #7 into liner to create hole #8.
8. Install mud flap hole #7 through liner hole #8 using a machine screw (e) and flat washer (a) and secure with a flat washer (c), lock washer (g), and hex nut (h)
9. Ensure that the mud flap has remained square. Tighten all fasteners.
10. Repeat procedure for the passenger side.

Install U-clip on Metal Tab Behind Liner

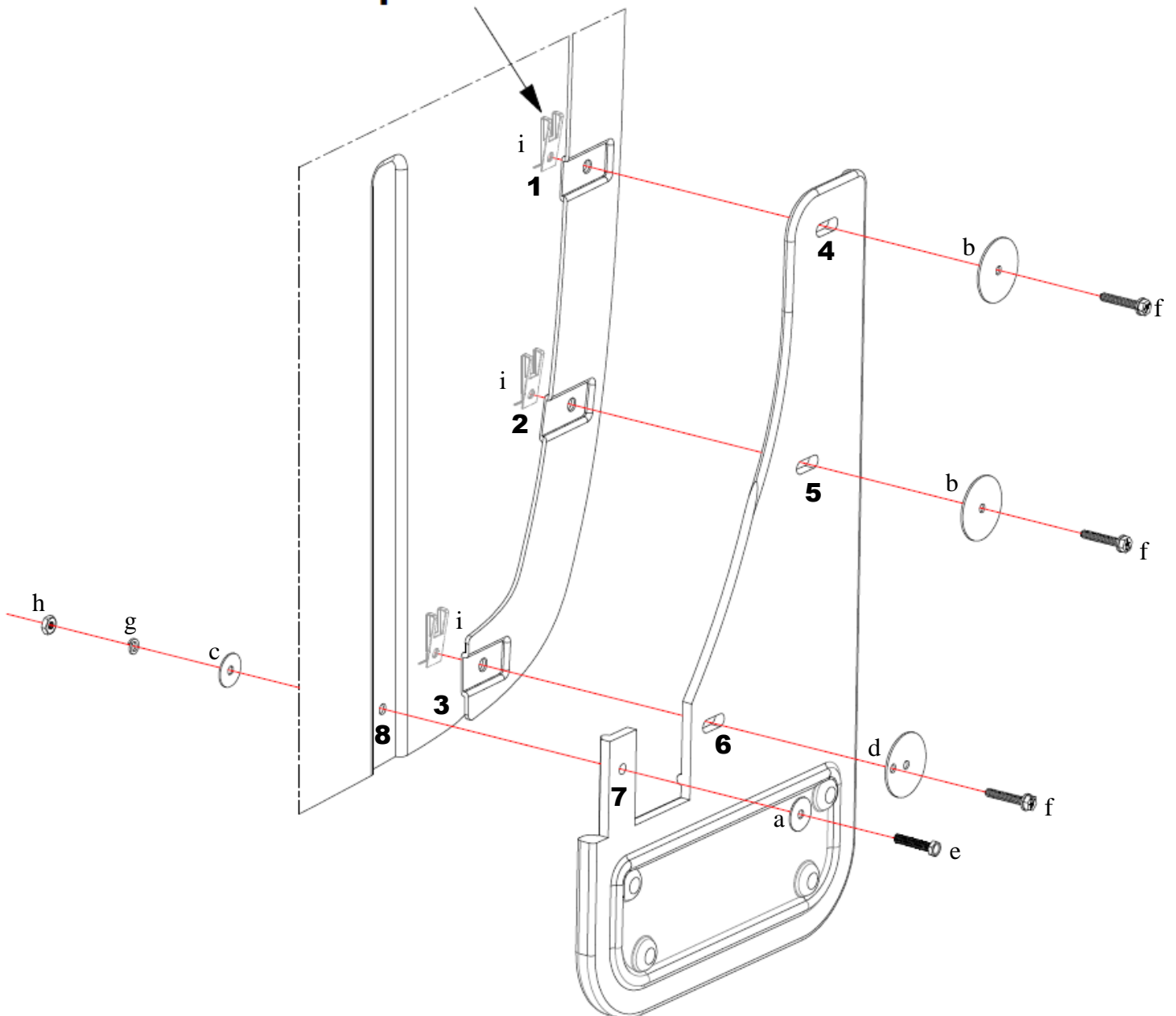

Please check out our YouTube channel to see an install video for this application.





**2020 Escape
Mud Flap Set, Rear
Mounting Diagram & Instructions
GCR404R**

IMPORTANT:

Manufacturer is not responsible for negligent use of vehicle with mud flaps installed, including over-tightening of screws and bolts causing damage to vehicle or mud flaps.



TOOLS REQUIRED-

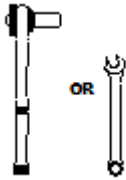

5/16" Open Wrench or
Socket Wrench

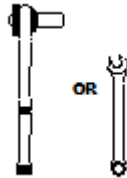

3/8" Open Wrench or
Socket Wrench



Push Pin
Removal Tool

FLAPS

(1) Flap Assembly,
Rear, DS

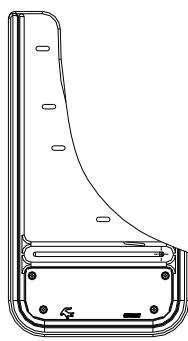

(1) Flap Assembly
Rear, PS

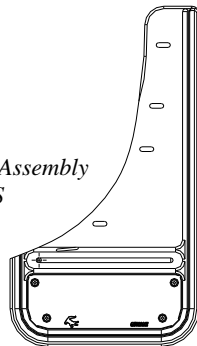

(1) Brace
DS, Rear
Part #768529



(1) Brace
PS, Rear
Part #768530



PARTS BAG #768532

a) (4) Washer, Flat
0.203" x 1", Blk Oxid.
Part #018070

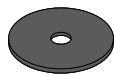

b) (4) Washer, Flat
0.203" x 1.5", Blk Oxid.
Part # 018072

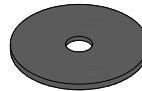

c) (4) Washer, Flat
0.203" x 0.781" SS
Part # 018018

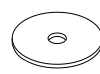

d) (4) Washer, HDPE
0.313" x 1" x 0.25"
Part #018036

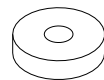

e) (2) Screw, Machine
18-SS, 10-24 x 1, Hex Hd
Part #012022

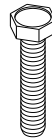

f) (8) SS Bolt, Hex Flange
M4.2 x 1", Black
Part # 016041

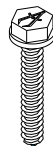

g) (2) Washer, Lock
18-8SS, Helicoil
Part #024001



h) (2) Nut, Hex
#10-24, SS
Part #025003



i) (8) Spring Nut
#8, 9/16" Reach
Part #028004



INSTALLATION (For ease of installation it is suggested that the wheel be removed)

2. Before you install your Mud Flap Set, see the diagram and parts list for all necessary parts. Start on the driver's side.
2. Remove the 4 factory push pins from the inner fender well on holes #1 to #4, and factory bolt from underside of fender.
3. Gently pull the liner away to install spring nuts (i) on recessed factory tabs, which previously contained the factory push pins.



4. Slide the brace through mud flap slot #9 and fasten through brace hole #12 and mud flap hole #10 using a machine screw (e) and flat washer (c). Secure with a flat washer (c), lock washer (g), and hex nut (h).
5. Loosely install mud flap holes #5 & #6 to factory holes #1 & #2 through spring nuts (i) using a stainless steel bolt (f) and flat washer (b)
6. Loosely install mud flap holes #7 & #8 to factory holes #3 & #4 through a flat washer spacer (d) and spring nut (i) using a stainless steel bolt (f) and a flat washer (a)
7. Using a square or bubble level, ensure that the mud flap is level. Tighten all fasteners.
8. Reinstall factory bolt on underside of fender through the brace hole #11.
9. Ensure that the mud flap has remained square. Tighten all fasteners.
10. Repeat procedure for the passenger side.

Install U-clip on Metal Tab Behind Liner

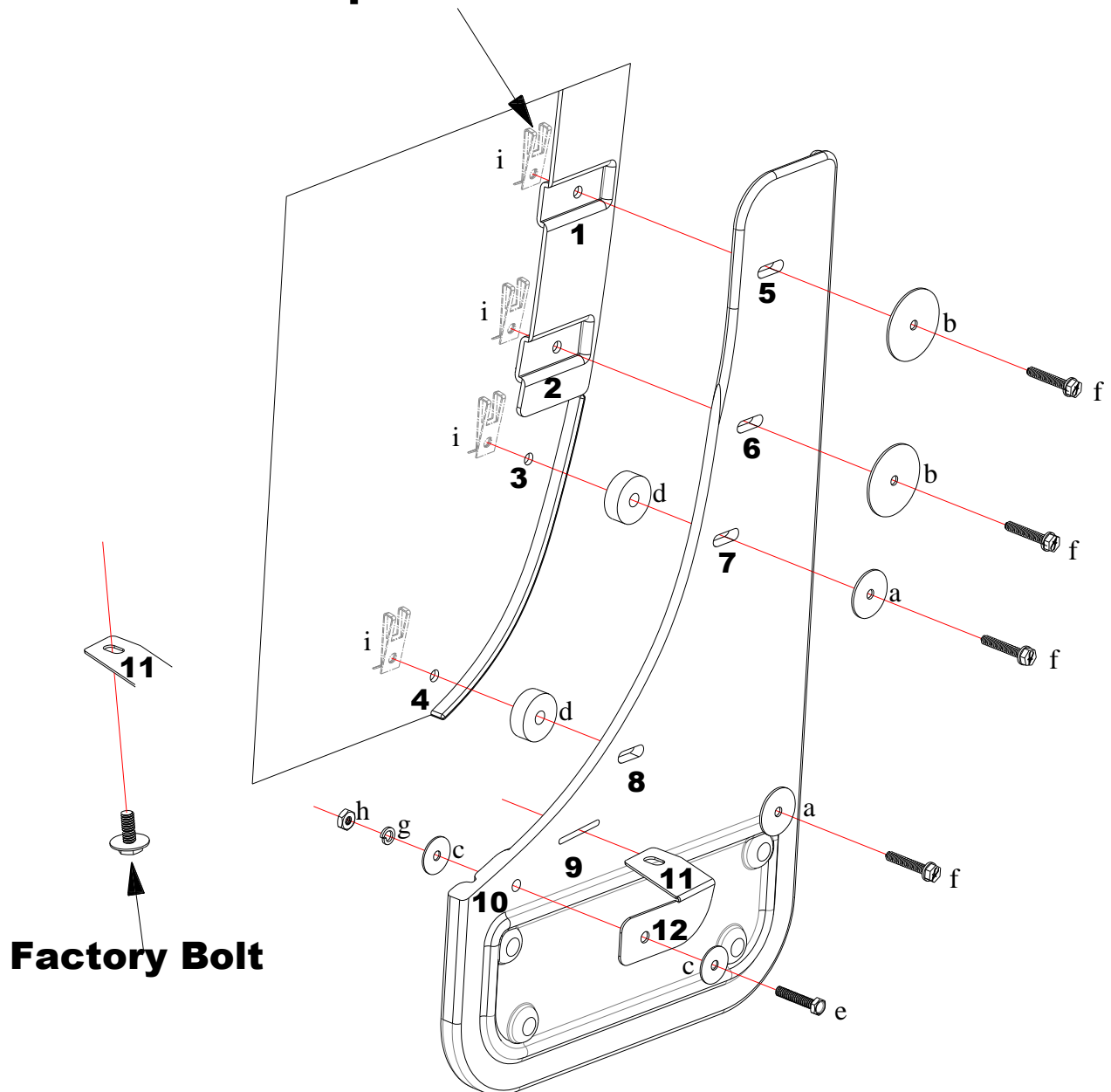

Please check out our YouTube channel to see an install video for this application.

