



By *Innovative Creations International*

08-C FORD SUPERDUTY SUPER CAB #760044

Qty	Part #	Description	Qty	Part #	Description
1	Assembled	Front Driver Side Bracket	2	014021	5/8" x 2" Cap Screw
1	Assembled	Front Passenger Side Bracket	2	024003	5/8" Lock Washer
1	Assembled	Middle Driver Side Bracket	2	018045	5/8" Flat Pltd Washer
1	Assembled	Middle Passenger Side Bracket	4	762236	3/8 x 1" T-bolt
1	Assembled	Rear Driver Side Bracket	4	025015	3/8" Hex Nut
1	Assembled	Rear Passenger Side Bracket	12	018046	3/8" Flat Pltd Washer
6	014022	Cap Screw 5/16"	12	024006	3/8" Lock Washer
6	018047	3/8" Flat Pltd Washer	8	014012	3/8" x 1-1/2" Cap Screw
6	028005	5/16" Spring Nut	18.25'	080407	Bulb Seal

Note Orientation
of Bracket Flanges
and Braces

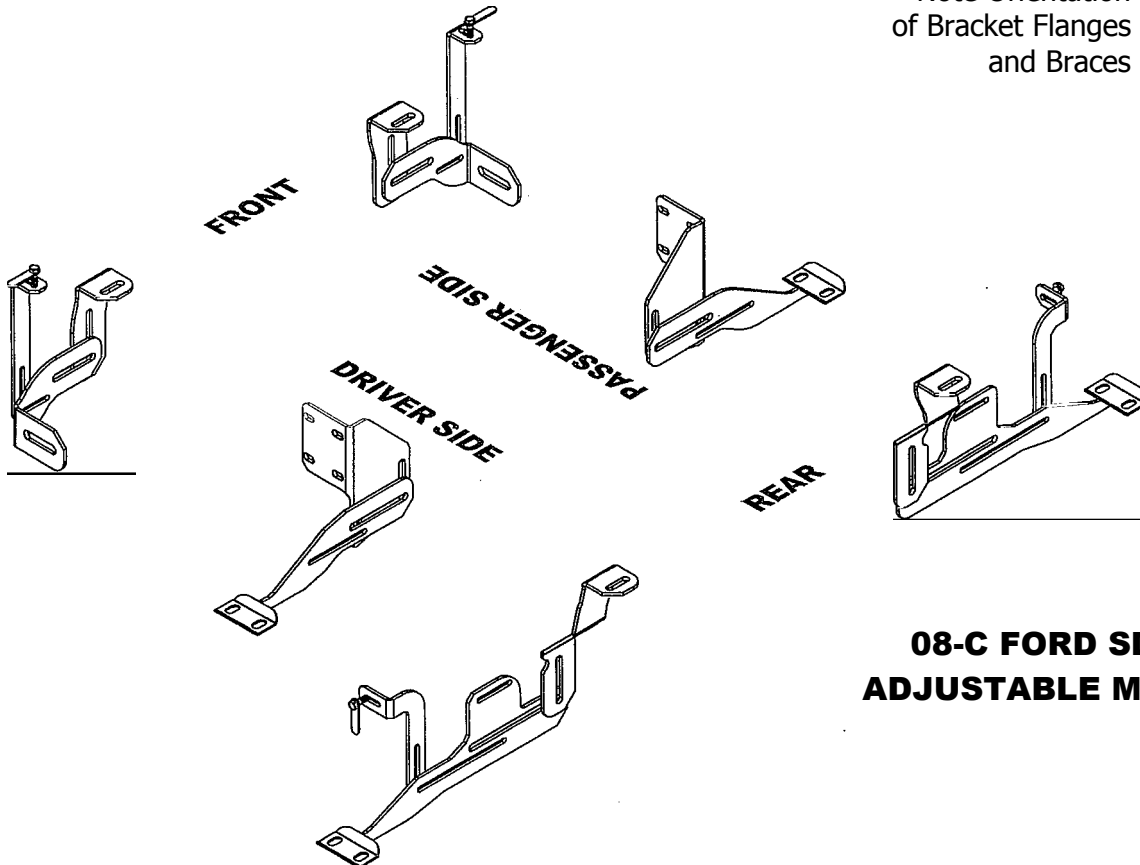

08-C FORD SD CC SB ADJUSTABLE MOUNTS

Step 1 Remove front cab mount bolt and install front bracket with the factory bolt.

Step 2 Remove Middle cab mount bolt and install middle bracket loosely with the factory bolt. Repeat process for the rear brackets.

Step 3 Lay assembled board on the middle and rear brackets and use a jackstand to steady if available, install board to front bracket using 5/8" x 2" cap screw with 5/8" flat washer. Level to body line and tighten.

Step 4 Install front bracket support strap using 3/8" x 1-1/2" T-bolt and 3/8 x 1-1/2" cap screw with 3/8" flat washer, 3/8" lock washer and 3/8" hex nut.

Step 5 Install middle bracket support strap using 3/8" x 1-1/2" T-bolt and 3/8" x 1-1/2" cap screw with 3/8" flat washer, 3/8" lock washer and 3/8" hex nut and repeat on rear bracket into the bottom of tube. Repeat process for opposite side.

Step 6 Remove any plastic wrap around bracket saddles and install 3/8" x 1-1/2" cap screws with 3/8" flat washer and 3/8" lock washer into the bottom of tube. Repeat process for opposite side.

Strip board of any plastic covering, check all nuts and bolts for tightness and repeat procedure for the opposite side.