



# GATORGEAR NERF BOARD



## 2014, FORD SUPER DUTY CREW CAB, SB #760063

Carton 1 of 2 - Front & Rear Tube Assembly  
#760522 & 760803

Carton 2 of 2 - Bracket and Fastener Kit  
#760794

Qty.	Part#	Description	Qty.	Part#	Description
1	Assembled	Front Driver Side Bracket	2	018045	5/8" Flat Washer
1	Assembled	Front Passenger Side Bracket	14	018046	3/8" Flat Washer
1	Assembled	Middle Driver Side Bracket	2	024003	5/8" Lock Washer
1	Assembled	Middle Passenger Side Bracket	14	024006	3/8" Lock Washer
1	Assembled	Rear Driver Side Bracket	6	025015	3/8" Hex Nut
1	Assembled	Rear Passenger Side Bracket	21.25'	080407	Bulb Seal Push-On
8	014012	3/8" x 1-1/2" Cap Screw	6	762236	3/8" x 1-1/2" T-bolt
2	014021	5/8" x 2" Cap Screw			

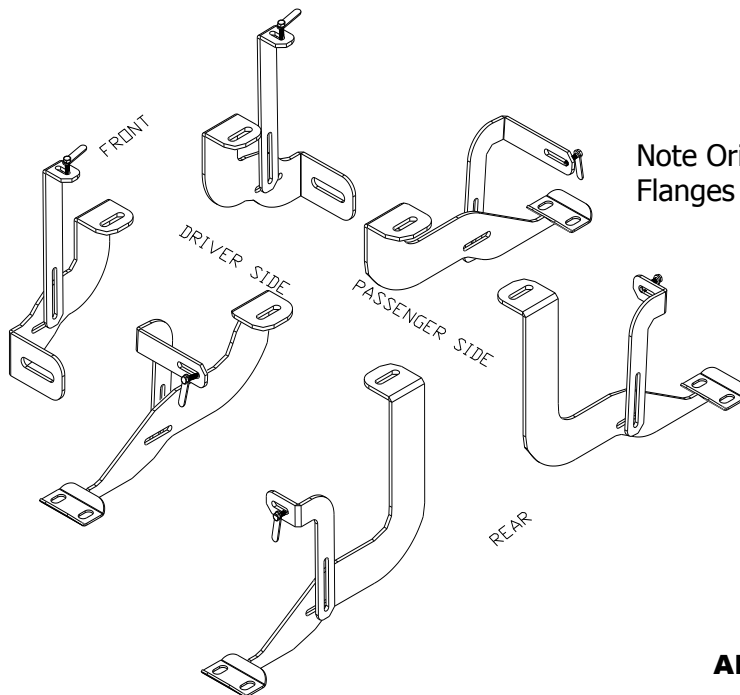

Note Orientation of Bracket Flanges and Braces

### 2014 FORD SD CC SB ADJUSTABLE MOUNTS

#### Note: Start on Driver Side

**Step 1:** Remove front cab mount bolt and install pre-assembled bracket loosely with the factory bolt. Watch out for bracket orientation. Set up the front bracket support strap using #762236 T-Bolt with #018046 3/8" flat washer, #024006 3/8" lock washer and #025015 3/8" hex nut.

**Step 2:** Repeat process for rear bracket.

**Step 3:** Lay pre-assembled board on the rear bracket. Make sure board will not fall down. You should utilize a jack to avoid the board from falling down. Line board up with the front bracket and set up #014021 5/8" cap screw with #018045 flat washer and #024003 5/8" lock washer. Do not tighten up the bolts, you need to level the board later.

**Step 4:** Remove any plastic wrap around bracket saddles.

**Step 5:** Use #014012 3/8" cap screw with #018046 flat washer and #024006 lock washer to install board to rear bracket loosely.

**Step 6:** Remove middle cab mount bolt and install middle bracket with factory bolt loosely. Install board to bracket like you did with the rear bracket. Set up the middle bracket support strap using #028005 5/16" spring nut with #014022 5/16" cap screw and #024002 5/16" lock washer.

**Step 7:** Level board to Cab and tighten up the 4x #014012 cap screws. Secure all other bolts now.

**Step 8:** Repeat for Passenger Side.