

IMPORTANT:

Manufacturer is not responsible for negligent use of vehicle with Skid Plate Installed, Including over-tightening of screws and bolts causing damage to vehicle or guard.

Components

(1) Skid Plate, Clinch Nuted	Part# 702299	(1) Parts Bag	Part #702303
(1) Access Plate	Part# 702302		

Parts Bag #702303

(2) Capscrew, Pltd, 3/8-16unc x1.5"	Part# 014012	(3) Capscrew, SS, 1/4"-20 x 3/4", Hex Head	Part# 014034
(3) Washer, Flat, 0.281"ID x 1"OD, 18ga, SS	Part# 018028	(2) Washer, Flat, Zinc PLTD, 3/8"IDx0.8"OD	Part# 018046
(3) Washer, Lock, SS, Helicoil, 1/4"	Part# 024000	(2) Washer, Lock, SS, 3/8", Helicoil	Part# 024006
(1) Grommet, Button Type, 3/16" Groove x 5/16"	Part# 080647	(1) Wire Tie, Plastic, 4"	Part# 054011
(2) Nut, Hex, 3/8"-16unc, Pltd	Part# 025015		

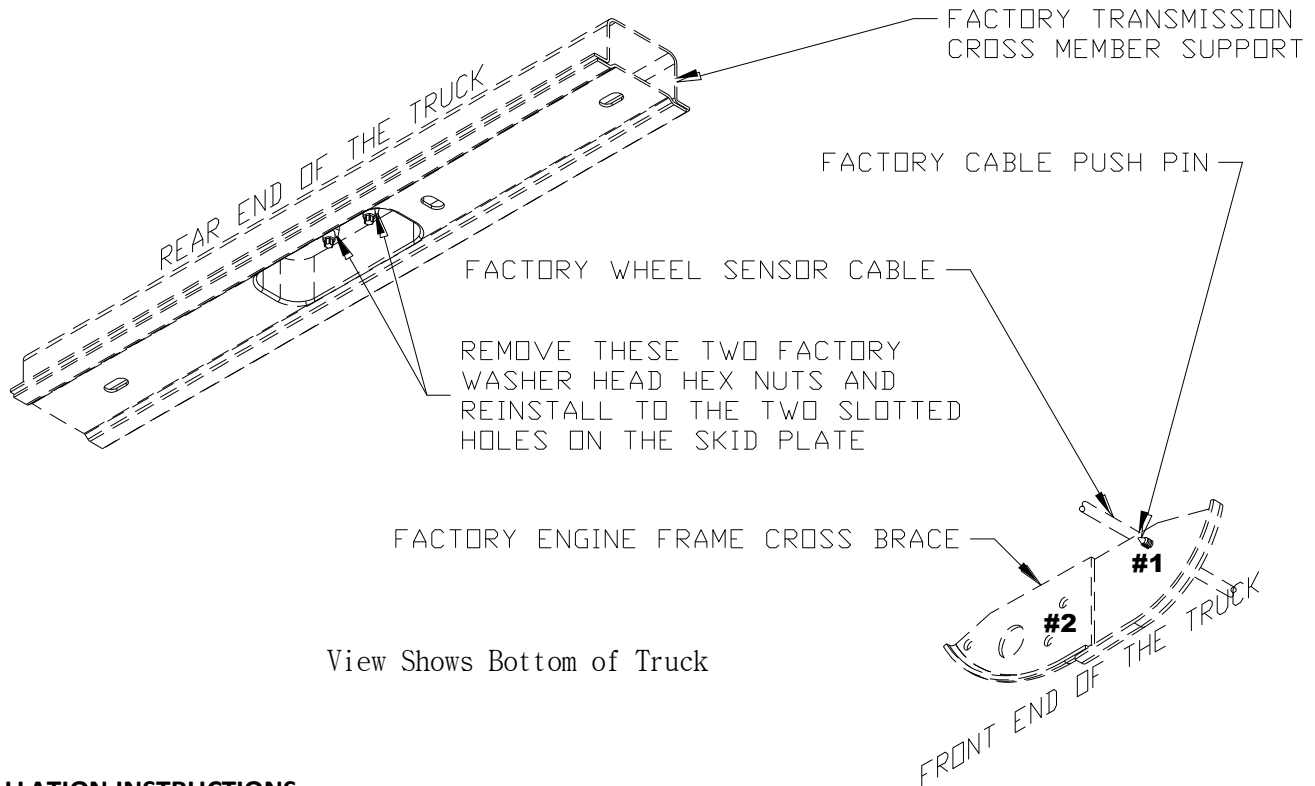

View Shows Bottom of Truck

INSTALLATION INSTRUCTIONS:

Refer to Diagram #1

1. Remove the factory cable push pin with the wheel sensor cable from the factory engine frame cross brace on hole #1.
2. Remove the two factory washer head hex nuts from the factory transmission cross member support and set aside.

Refer to Diagram #2

1. Ensuring that the wheel sensor cable is clear of the hole, use a 7/16" drill bit to widen hole #1 on the factory engine frame cross brace.
2. Note: Ensure that the rear end of the skid plate is supported while proceeding with step two. Mount the front end of the skid plate on factory holes #1 & #2 with two 3/8" x 1-1/2" capscrews, two 3/8" flat washers, two 3/8" lock washers & two 3/8" hex nuts. Loosely secure at this point.
3. From the other end of the skid plate, insert the two factory washer head hex nuts through the slotted holes in the skid plate and reinstall into the factory transmission cross member support. Tighten the two screws on the front end holes #1 & #2.
4. Insert the rubber bumper from the top down on the skid plate hole #3.
5. Secure the oil pan access door with three 1/4" x 3/4" capscrews, three 1/4" lock washers and three 1/4" flat washers.

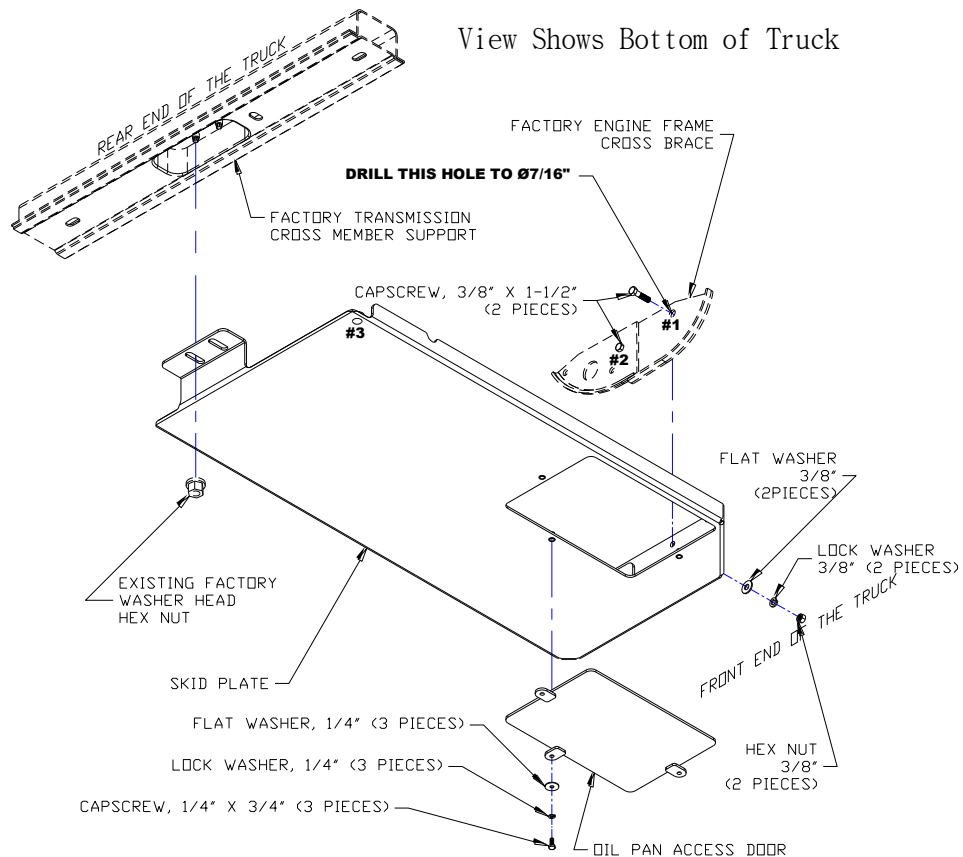

Refer to Diagram #3

1. Secure the wheel sensor cable with a tie strap to the skid plate hole #4.

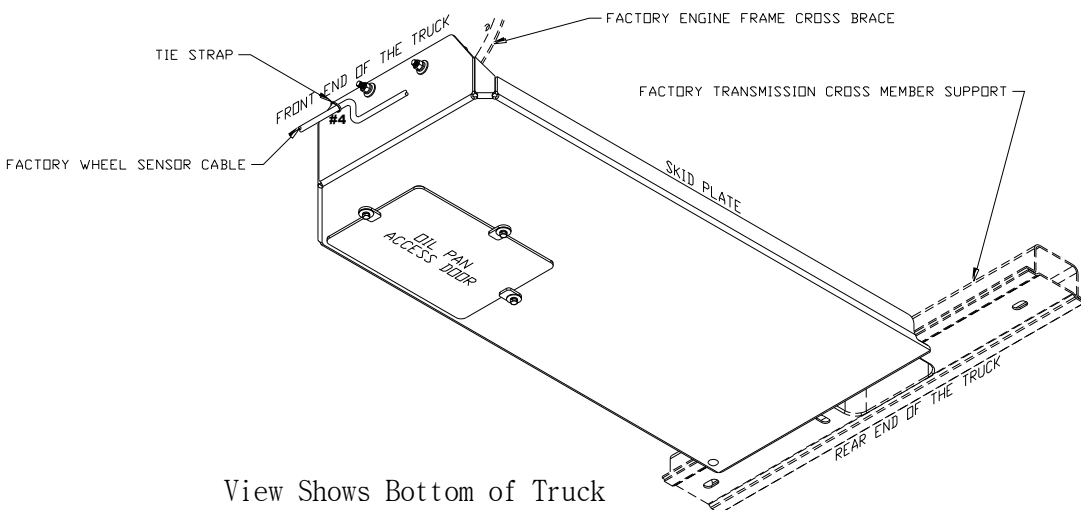

View Shows Bottom of Truck