



# 2010-2020, DODGE HD LB DUALLY 19" Mud Flap Set, Ram Vertical Black Wrap Mounting Diagram & Instructions

**Part #  
GB756666**

**(Includes bracket kit #756197)**

## IMPORTANT:

**The manufacturer is not responsible for negligent use of vehicle with mud flaps installed, including over-tightening of screws and bolts causing damage to vehicle or mud flaps.**

## TOOLS REQUIRED



Electric or re-chargeable  
1/2" or 3/8" drill.



1/4  
drill bit

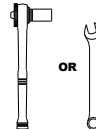

3/8" and 5/16" wrench  
or socket set



3/8" Socket Drivers

## SCREWS / FASTENERS / WASHERS / FLAPS - PARTS BAG # 755533

a) (1) Flap Assembly,  
Rear, RH

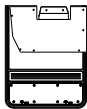

b) (1) Flap Assembly  
Rear, LH

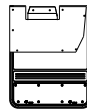

c) (6) Washers, Flat  
0.281" x 1"  
Part #018028



d) (18) Nut, Hex, SS  
#10  
Part #025003



e) (18) Lock Washer  
#10  
Part #025003



f) (40) Flat Washer  
0.203 x 1" 18ga  
Part #0018031



g) (2) Machine Screw  
#10 x 1.5"  
Part #012027



h) (16) Screw Machine  
#10 x 1"  
Part #012022



i) (6) Screw Tek  
1/4 x 1 - 1/4  
Part #010011



j) (1) Brkt, Z, DS  
Part # 750433

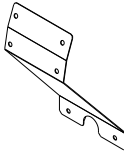

k) (1) Brkt, Z, PS  
Part # 750434

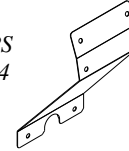

**Prior to installation of your Mud Flap, see the above diagrams and parts list for all necessary parts.  
Start on the driver side.**

## INSTALLATION

*For ease of installation, it is suggested that the wheel be removed.*

1. Before installation, peel protective plastic away from stainless steel.
2. Remove factory harness mounts A & B with harness and reinstall to the "Z" bracket holes C & D.
3. Bolt the upper holes of the "Z" bracket to the existing factory push screw holes A & B with two machine screws, four flat washers (0.203" x 1") two lock washers and two hex nuts.
4. Remove the factory screws #10 & #11 on the wheel flare as shown on the diagram and reinstall the two factory screws with two flat washers (0.203" x 1") on holes #1 and #2 through the stainless steel mount into the factory holes #10 and #11, loosely secure at this point.

- Square the flap with the tire and push the flap up against the wheel flare then secure the flap with three tek screws and three flat washers (0.281" x 1") along the wheel flare as shown on the diagram. Now add washer, and tighten the two factory screws on holes #1 & #2.
- Drill a 1/4" hole (7 places) from holes #3 to #9 through the factory tub liner then fasten holes #5 and #6 with two machine screws, the long screw used on hole #5, four flat washers (0.203 x 1"), two lock washers & two hex nuts and the remaining holes #3, #4 & #7 to #9 with five machine screws, ten flat washers (0.203" x 1"), five lock washers & five hex nuts.

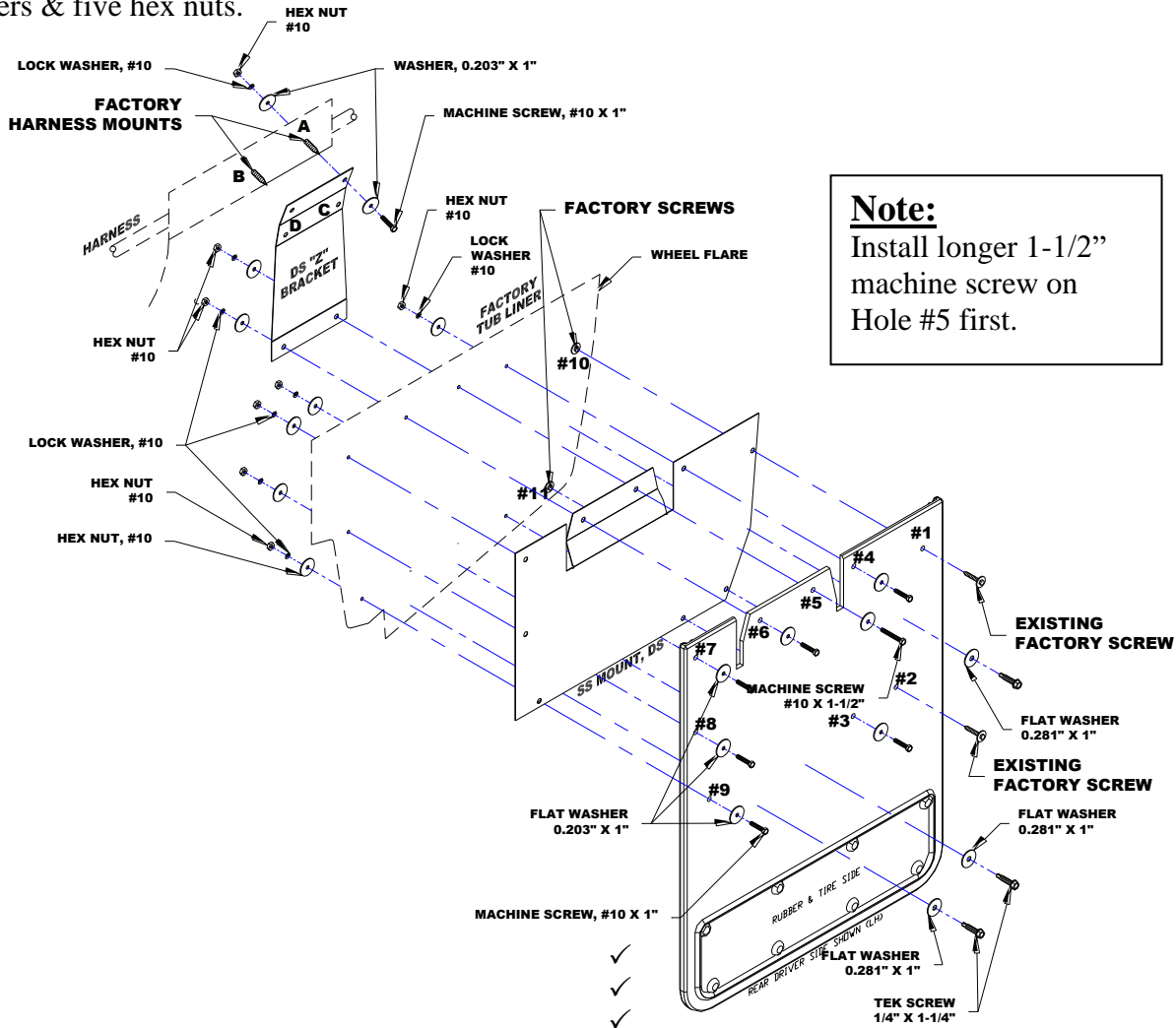

**Note:**  
Install longer 1-1/2" machine screw on Hole #5 first.

✓ Check all fasteners for tightness. Repeat procedure on the passenger side

**MAINTENANCE TIPS**

**Rubber Care**

Maintaining your rubber mud flaps is the same as looking after your tires. Use soap and water to remove road dirt and debris and then clean rubber with any good rubber weather / wear protector that you would use on your tires. All Gatorback Mud Flaps are made from new virgin rubber for long lasting great looks.

**Stainless Steel Care**

Keeping your mud flaps looking great requires proper care to be taken with your stainless steel - the same care that you would take to look after the paint on your truck. High amounts of salt will deteriorate even the finest stainless steel if it is continuously abused. Wash the stainless steel on your mud flaps from time to time to remove any road grime or salt. Autosol can transform even the toughest cases.

Please check out our YouTube channel to see an install video for this application.

